

**FERGUSON TOWNSHIP BOARD OF SUPERVISORS**  
**Regular Meeting Agenda**  
**Monday, May 3, 2021, 7:00 PM**

**Join Zoom Meeting:**

<https://us02web.zoom.us/j/84299615179>

**Meeting ID: 842 9961 5179**

**[Zoom Access Instructions](#)**

**I. CALL TO ORDER**

**II. PLEDGE OF ALLEGIANCE**

**III. CITIZENS INPUT**

**IV. APPROVAL OF MINUTES**

1. April 19, 2021, Board of Supervisors Regular Meeting Minutes

**V. SPECIAL REPORTS**

- a. COVID-19 (Coronavirus) Response Report
- b. Centre Region Parks and Recreation Authority Report
- c. First Quarter Financial Report

**VI. PROCLAMATIONS**

- a. 2021 Public Works Week
- b. 2021 Emergency Medical Services Week

**VII. UNFINISHED BUSINESS**

1. Public Hearing – Terraced Streetscape District Ordinance Amendment

**VIII. NEW BUSINESS**

1. Consent Agenda
2. Public Hearing – Disposition of Public Records Resolution
3. Public Hearing – Official Township Plant List Resolution
4. Request for Variance – 310 Marengo Lane

**IX. REPORTS**

1. COG Committee Reports
2. Other Regional Reports
3. Staff Reports

**X. COMMUNICATIONS TO THE BOARD**

**XI. CALENDAR ITEMS – MAY**

**XII. ADJOURNMENT**



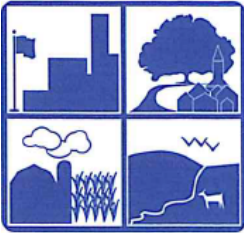

# TOWNSHIP OF FERGUSON

3147 Research Drive • State College, Pennsylvania 16801  
Telephone: 814-238-4651 • Fax: 814-238-3454  
[www.twp.ferguson.pa.us](http://www.twp.ferguson.pa.us)

## BOARD OF SUPERVISORS Regular Meeting Agenda Monday, May 3, 2021 7:00 P.M.

### I. CALL TO ORDER

### II. PLEDGE OF ALLEGIANCE

### III. CITIZEN'S INPUT

### IV. APPROVAL OF MINUTES

1. April 19, 2021, Board of Supervisors Regular Meeting Minutes

### V. SPECIAL REPORTS

40 minutes

1. COVID-19 (Coronavirus) Response Report – David Pribulka, Township Manager
2. Centre Region Parks and Recreation Authority Report – Bill Keough
3. First Quarter Financial Report – Eric Endresen, Director of Finance

### VI. PROCLAMATIONS

#### 1. 2021 PUBLIC WORKS WEEK

*David Pribulka, Township Manager*

5 minutes

#### **Narrative**

Provided with the agenda is a copy of a proclamation designating May 16<sup>th</sup> to May 22<sup>nd</sup> to be 2021 Public Works Week in Ferguson Township. This year's theme is "Stronger Together" and calls on citizens to think about the role Public Works plays in creating a great place to live.

[American Public Works Association "National Public Works Week"](#)

*Recommended motion: That the Board of Supervisors adopt the proclamation designating May 16 to May 22 as 2021 Public Works Week in Ferguson Township.*

#### **Staff Recommendation**

That the Board of Supervisors **adopt** the proclamation.

**2. 2021 EMERGENCY MEDICAL SERVICES WEEK**

5 minutes

**Narrative**

Provided with the agenda is a copy of a proclamation designating May 16<sup>th</sup> to May 22<sup>nd</sup> to be 2021 Emergency Medical Services Week in Ferguson Township. This year's theme is "This is EMS: Caring for Our Communities" and is an opportunity to recognize and acknowledge prehospital and hospital EMS practitioners for the many hours they spend preparing for and delivering care to the residents and visitors within our community.

*Recommended motion: That the Board of Supervisors adopt the proclamation designating May 16 to May 22 as 2021 Emergency Medical Services Week in Ferguson Township.*

**Staff Recommendation**

That the Board of Supervisors **adopt** the proclamation.

**VII. UNFINISHED BUSINESS**

**1. A PUBLIC HEARING ON AN ORDINANCE OF THE TOWNSHIP OF FERGUSON, CENTRE COUNTY, PENNSYLVANIA, AMENDING CHAPTER 27, ZONING; PART 3, RESIDENTIAL PLANNED DEVELOPMENT AND MIXED USE; SECTION 304, TERRACED STREETScape (TS) DISTRICT BY AMENDING §27-304.3.B.2. BUILDING HEIGHT INCENTIVES AND REPEALING IT IN ITS ENTIRETY.**

10 minutes

*Jenna Wargo, Director of Planning & Zoning*

**Narrative**

On March 15, 2021, the Board of Supervisors authorized staff to advertise a public hearing to amend §27-304.B.(2). Building Height Incentives and remove it in its entirety. Provided with the agenda is the draft amendment as advertised to remove this provision of the Terraced Streetscape District (TSD) ordinance. While staff remains concerned about the implications of removing the incentive and is recommending that the Board establish a minimum number of shared parking spaces to utilize the building height incentive, it is understood that incentives will be revisited with the pending TSD amendment. Therefore, staff is recommending adoption of the ordinance as presented. This amendment was provided to and reviewed by Centre County Planning, Centre Regional Planning Agency and Ferguson Township Planning Commission. Those reviews are provided with the agenda.

*Recommended motion: That the Board of Supervisors adopt the ordinance amending Chapter 27, Section 304(3)b.2., Building Height Incentives by repealing it in its entirety.*

**Staff Recommendation**

That the Board of Supervisors **adopt** the ordinance.

**VIII. NEW BUSINESS**

**1. CONSENT AGENDA**

5 minutes

- a. Sponsorship Request – Ferguson Township Elementary PTO "Fun Run"
- b. Harner 4-Lot Subdivision Surety Reduction - \$536,365.54
- c. Board Member Request – Grass and Weed Ordinance Amendment
- d. Voucher Report – March 2021
- e. Treasurer's Report – February 2021 for Acceptance

**2. A PUBLIC HEARING ON A RESOLUTION OF THE TOWNSHIP OF FERGUSON, CENTRE COUNTY, PENNSYLVANIA, AUTHORIZING THE DISPOSITION OF SPECIFIC PUBLIC RECORDS IN ACCORDANCE WITH THE PROCEDURES SET FORTH IN THE RETENTION AND DISPOSITION SCHEDULE FOR RECORDS OF PENNSYLVANIA MUNICIPALITIES ISSUED JULY 16, 1993 AND AS AMENDED DECEMBER 16, 2008.**

*David Pribulka, Township Manager*

5 minutes

**Narrative**

Provided with the agenda is a copy of a resolution advertised for public hearing providing for the disposition of certain records retained by the Township but scheduled for disposition in accordance with the Retention and Disposition Schedule for Records of Pennsylvania Municipalities. Annually, Township staff completes a listing of records that are required to be disposed of in accordance with the municipal records manual. Attached to the Resolution as Exhibit "A" is the list of storage boxes and their contents to be disposed.

*Recommended motion: That the Board of Supervisors adopt the resolution authorizing the disposition of specific public records in accordance with the retention and disposition schedule for records of Pennsylvania Municipalities.*

**Staff Recommendation**

That the Board of Supervisors **adopt** the resolution.

**3. A PUBLIC HEARING ON A RESOLUTION OF THE TOWNSHIP OF FERGUSON, CENTRE COUNTY, PENNSYLVANIA AMENDING RESOLUTIONS 1999-36, 2000-22, AND 2020-41, THE OFFICIAL TOWNSHIP PLANT LIST.**

*David Pribulka, Township Manager*

5 minutes

**Narrative**

Provided with the agenda is a copy of the resolution advertised for public hearing amending several resolutions and establishing a revised Official Township Plant List. The new Plant List includes Native Pussy Willow (*Salix Discolor*) and was reviewed and recommended for approval by the Ferguson Township Tree Commission on Monday, April 19<sup>th</sup>.

*Recommended motion: That the Board of Supervisors adopt the resolution amending the Official Township Plant List.*

**Staff Recommendation**

That the Board of Supervisors **adopt** the resolution.

**4. REQUEST FOR ZONING/VARIANCE – 310 MARENGO LANE, 24-006A,081-,0000-**

*Jenna Wargo, Director of Planning & Zoning*

5 minutes

**Narrative**

Zachary Maser—310 Marengo Lane (24-006A-081), zoned Single Family Residential (R1), is requesting a variance from §27-701.3.C.1—Use Limitations and §27-701.3.I.—Use Buffer to allow for the applicant to repair and pave the existing driveway that is located in the floodplain.

*Recommended motion: That the Board of Supervisors remain neutral on the request for variance at 310 Marengo Lane.*

**Staff Recommendation**

That the Board of Supervisors *remain* neutral on the request for variance.

**IX. STAFF AND COMMITTEE REPORTS**

- 1. **COG COMMITTEE REPORTS** 10 minutes
  - a. Executive Committee
  - b. CCMPO Coordinating Committee
- 2. **OTHER COMMITTEE REPORTS** 5 minutes
- 3. **STAFF REPORTS** 15 minutes
  - a. Manager's Report
  - b. Public Works Director
  - c. Planning and Zoning Director

**X. COMMUNICATIONS TO THE BOARD**

**XI. CALENDAR ITEMS – MAY**

- a. Ferguson Township upcoming committee meetings:
  - 1. Planning Commission, Mondays, May 10 and May 24, 6PM
  - 2. Tree Commission, Monday, May 17, 4PM
  - 3. Board of Supervisors, Monday, May 17, 7PM
  - 4. Parks & Recreation Committee, Thursday, May 20, 4PM
  - 5. Pine Grove Mills SAP Advisory Committee, Thursday, May 27, 4PM
- b. Ferguson Township Virtual Bike Chat, Thursday, May 20, 12:30PM

**XII. ADJOURNMENT**

## FERGUSON TOWNSHIP BOARD OF SUPERVISORS

Regular Meeting  
Monday, April 19, 2021  
7:00 PM

### ATTENDANCE

The Board of Supervisors held its second regular meeting of the month on Monday, April 19, 2021, via Zoom in a webinar format. In attendance were:

<b>Board:</b>	Laura Dininni, Chair	<b>Staff:</b>	Dave Pribulka, Township Manager
	Lisa Strickland, Vice Chair		Dave Modricker, Director of Public Works
	Steve Miller		Chris Albright, Chief of Police
	Prasenjit Mitra		
	Patty Stephens		

Others in attendance included: Rhonda Demchak, Recording Secretary; Mr. Bill Keough, Ferguson Township Resident and Planning Commission member; Tracy Small, Centre County CIT Coordinator; Ann Bergevin, Ferguson Township Resident; John Simbeck, Ferguson Township Resident; Dr. Nalini Krishnankutty, Governor's Commission on Asian Pacific American Affairs and a resident of State College; Don Hahn, Governor's Commission on Asian Pacific American Affairs and a resident of State College; Pastor Paul Tomkiel, Ferguson Township Resident; Liz Grove, Ferguson Township Resident; Ms. Pam Steckler, Ferguson Township Resident; Robert Zeigler, President, Millheim Borough Council

### I. CALL TO ORDER

Ms. Strickland called the Monday, April 19, 2021, regular meeting to order at 7:00 p.m.

Mr. Pribulka noted that the Board of Supervisors meeting had been advertised in accordance to the PA Sunshine Act as a virtual meeting via Zoom in a webinar format. There was also an audio conference bridge that was accessible by dialing the Ferguson Township's main line at 814-238-4651 and then dialing extension 3799. Persons attending the webinar as members of the public and wanted to participate were asked to enter their name, municipality, and topic by utilizing the Q&A bubble at the bottom of the screen. Mr. Pribulka noted that attendees will not be permitted to speak unless addressed by the Chair. Mr. Pribulka will share more information on how attendees can interact with the Board at the appropriate time of the meeting. C-NET is recording as well. Mr. Pribulka took Roll Call and there was a quorum.

### II. THE PLEDGE OF ALLEGIANCE

### III. CITIZENS INPUT

None.

### IV. APPROVAL OF MINUTES

Ms. Dininni moved that the Board of Supervisors **approve** the Regular meeting Minutes of April 5, 2021; Special Meeting – Whitehall Road Regional Park meeting minutes on March 29, 2021; and the Work Session meeting minutes on March 31, 2021. Ms. Stephens seconded the motion. The motion passed unanimously.

### V. SPECIAL REPORTS

a) COVID-19 (Coronavirus) Response Report

Mr. Pribulka noted that local or regional updates can be found on the Centre Region Ready [Facebook page](#) or the [COG website page](#). Also, information can be found on the [Township website](#) and [State College Borough website](#).

Pennsylvania has moved into Phase 2 of the vaccine rollout plan that allows anyone 16 and up to receive. More information can be found at the [Pennsylvania Department of Health](#) or by calling 1-877-724-3258. Effective April 4, 2021, restaurants were able to resume bar service; alcohol service is allowed without the purchase of food; the curfew for removing alcoholic drinks from tables was lifted; and indoor dining capacity is raised to 75 percent for those restaurants that are currently self-certified. The governor also announced revised maximum occupancy limits for indoor events to allow for 25% of maximum occupancy, regardless of venue size, and maximum occupancy limits for outdoor events to allow for 50% of maximum occupancy, regardless of venue size. Maximum occupancy is permitted only if attendees and workers are able to comply with the 6-foot physical distancing requirement. Mr. Pribulka noted that all of the restrictions are still in place for the Township under the January 2021 reauthorized ordinance.

The Pennsylvania Emergency Management Agency and the Department of Health reopened the regional vaccination clinic at the Bryce Jordan Center since it was closed due to side effects with the Johnson & Johnson vaccine. The Moderna Vaccine will be the vaccine given by appointment only by calling 1-844-545-3450. The PA National Guard and the AMI Expeditionary Healthcare will be administering the doses at the Bryce Jordan Center.

There have been 15,744 confirmed cases county-wide, which is over 2,169 from Mr. Pribulka's report on April 5, 2021. There have been 66,724 negative cases in the State College. There have been 215 deaths attributed to the virus in Centre County. There have been 937,515 reported cases in Pennsylvania and an additional 171,706 probable cases. There have been 25,688 deaths.

Mr. Pribulka thanked the residences and business owners in Ferguson Township for their patience and understanding as the Township recovers.

b) Mental Health Taskforce Report

Chief Albright and Traci Small, Centre County CIT Coordinator presented the report that was included in the agenda packet. Chief Albright noted that in 2019 the State College Borough created the taskforce and more information can be found at their [website](#). In January 2021, Centre County received a grant from Substance Abuse and Mental Health Services Administration. The grant will provide technical assistance by analyzing strengths and identifying ways to enhance the crisis system.

Ms. Small offered insight and recommendations by the Taskforce. The grant is called the Building a Confidence Crisis Care System at Intercepts 01 and noted that the Intercepts 01 is when the calls come into the 911 center and then the police and first responders are sent. Ms. Small noted that the grant is being used to address some of the issues brought forth by the Mental Health Taskforce. The Taskforce is focusing on the following three goals:

1. Develop a co-responder model to assist law enforcement with crisis responses.
2. Develop data collection and sharing system.
3. Standardize consistent communication process across all agencies and departments.

Ms. Small noted that there was a virtual meeting in March that included the eight areas across the country that were awarded the grants. There will be a series of one-hour webinars called Asked the Expert in April/May 2021. Ms. Small stated that Huntingdon, Mifflin, and Juniata tri-county mental health providers were awarded a one-year grant through the PA Commission on Crime and Delinquency to start a co-responder program. The providers stated they are already seeing changes because the people in crisis are utilizing the program that is in place.

Ms. Dininni asked if the funding would be coming from the County. Ms. Small commented they are looking into where the funding will be coming from due to the size of each police department.

Ms. Strickland stated that she is pleased that Ferguson Township has a representative taking a part and is supportive of the initiative.

Chief Albright noted that on the Ferguson Township's Police Department website there is a link for [Resources for Mental Health](#).

## VI. PROCLAMATIONS

### a) May 2021 Asian Heritage Month Proclamation

Mr. Mitra presented the proclamation that was included in the agenda and noted that there are approximately 11% of Asian Americans living in Ferguson Township.

Mr. Mitra moved that Board of Supervisors **adopt** the proclamation designating May 2021 as Asian Heritage Month in Ferguson Township. Ms. Dininni seconded the motion. The motion passed unanimously.

## VII. UNFINISHED BUSINESS

### 1. Public Hearing – Recreation Fire Open Burn Ordinance

Chief Albright noted that provided with the agenda is a copy of an ordinance that was advertised for public hearing establishing additional fire code and safety regulations within Ferguson Township. The Board of Supervisors reviewed this draft ordinance during their March 15, 2021, regular meeting and authorized staff to advertise the ordinance for public hearing. The new regulations prohibit burning certain materials; and creates safety setbacks and prohibits burning during dry weather conditions.

Ms. Ann Bergevin, Ferguson Township Resident, expressed appreciation to everyone for their hard work regarding the ordinance change. Ms. Bergevin inquired why the prohibition of all-night smokers were not included in the ordinance. Mr. Pribulka stated that it was not included due to the difficulty of enforcing but the safety zone for smokers was included in the ordinance.

Mr. John Simbeck, Ferguson Township Resident, asked the Township to consider the size of the properties that are utilizing smokers, grills, etc. Mr. Simbeck stated that cooking in a smoker has been around for a very long time.

Ms. Dininni moved that the Board of Supervisors **adopt** the ordinance amending Chapter 10, Health and Safety by establishing additional fire code and safety regulations within Ferguson Township. Mr. Miller seconded the motion.

Ms. Strickland stated that the Board tried to strike a balance and if improvements or changes need to be made in the future, the Board will address. Ms. Dininni noted that the enforcement of the ordinance will be driven by residential complaints

ROLL CALL: Ms. Strickland – Yes: Ms. Dininni – Yes: Mr. Miller – Yes: Mr. Mitra – Yes: Ms. Stephens – Yes

### 2. Public Hearing – Resolution Condemning Violence Against Asian American Community



Mr. Mitra introduced the ordinance and noted that provided with the agenda is a copy of the resolution advertised for public hearing condemning acts of hatred, bias, and exclusionary behavior against the AAPI Community. This resolution was adopted in similar form by the Centre Region Council of Governments at the March 22, 2021 General Forum meeting. Judge Don Hahn and Dr. Nalini Krishnankutty are in attendance as representatives of the Governor's Commission on Asian Pacific American Affairs and are residents of the State College area.

#### Public Hearing

Dr. Krishnankutty thank the Board for considering adopting the resolution which condemns the acts of hatred, bias, and exclusionary behavior against persons of color especially against Asian Americans and Pacific Islanders. Dr. Krishnankutty stated that Ferguson Township is approximately 15.5% Asian American which is the largest minority in the Township, and they have been impacted with the hatred over the last year. Due to bullying, some parents are homeschooling their children in Pennsylvania. Dr. Krishnankutty stated that there is hope in the local region that the community and government are standing up against the hate and violence. Dr. Krishnankutty thanked the Board for the earlier proclamation designating May 2021 Asian Heritage Month. The celebration this year will be more vital since it's conception in 1992 and encouraged other institutions to organize events to celebrate Asian Heritage Month in May.

Judge Don Hahn thanked the Board and the Township for taking a stand against hate. Judge Hahn indicated that he is State College native and has always felt safe in the community, but not welcomed at times. Judge Hahn noted that by adopting the resolution Ferguson Township is sending a message to others that the Township is a welcoming community.

Mr. Mitra moved that the Board of Supervisors **adopt** the resolution condemning acts of hatred, bias, and exclusionary behavior against the AAPI Community. Ms. Dininni seconded the motion.

Ms. Stephens thanked the Board for the proclamation especially in light of the recent graffiti at the MLK Plaza in downtown State College and it is important to condemn this behavior.

Mr. Miller indicated there was a similar resolution four-years ago on hate and noted that he is discouraged that it needed to be amended. Mr. Miller noted that the resolution recognizes that the Township has a significant population of Asian and Asian Americans that contribute to the community and supports the community. Ms. Dininni read the resolution into the record and closed the public hearing.

ROLL CALL: Ms. Dininni – Yes: Mr. Miller – Yes: Mr. Mitra – Yes: Ms. Stephens – Yes: Ms. Strickland – Yes

#### 3. Public Hearing – Resolution Establishing Green Infrastructure Policy

Mr. Pribulka noted that the policy has been reviewed by the Board in September 2020 as well as the Parks and Recreation Committee and Centre Region Parks and Recreation. Most of the comments received as part of the discussions were incorporated into resolution. The copy of the resolution is provided in the agenda. Mr. Pribulka gave examples that included Cecil Irvin Park, Fairbrook Park, Tudek Park and Haymarket Park.

Public Hearing – There were no comments.

Ms. Dininni recommended removing the word "opinion" from vi.3 on page 3 of the policy. Ms. Dininni inquired about process and how to make a request. Mr. Pribulka noted the form has not

been developed but will create one for citizens requests. Mr. Pribulka stated it wouldn't be necessary for the Board to have a request form. Ms. Dininni inquired about interpretation of the operations and maintenance portion of the policy and the budget. Mr. Pribulka noted that in Fairbrook Park and Homestead Park CRPR does the maintenance, but in some areas such as the native garden in Cecil Irvin Park there needs to be more effort and expertise that the Township can provide. Mr. Pribulka noted that as for budgeting there shouldn't be a lot, but it will depend on labor and material.

Ms. Dininni moved that the Board of Supervisors **adopt** the resolution establishing a Green Infrastructure Policy as described in Exhibit "A" of the resolution. Mr. Stephens seconded the motion.

Mr. Miller stated that the policy is a great idea because he has been observing Haymarket Park evolve. Ms. Strickland also stated that the policy is great idea.

ROLL CALL: Mr. Miller – Yes: Mr. Mitra – Yes: Ms. Stephens – Yes: Ms. Strickland – Yes: Ms. Dininni – Yes

## VIII. NEW BUSINESS

### 1. Consent Agenda

- a. Contract 2020-C3, Pay App #4: \$19,693.48
- b. Special Events Permit – Overlook Heights Block Parties
- c. Special Events Permit – Glimcher Keystone Country Ride

Mr. Miller moved that the Board of Supervisors **approve** the Consent Agenda. Mr. Mitra seconded the motion. The motion passed unanimously.

### 2. Public Hearing – Resolution Authorizing Tourism Grant Application for Agritourism Event

Mr. Pribulka introduced the resolution and noted that provided with the agenda is a copy of the resolution advertised for public hearing authorizing the submission and matching funds for a grant application to the Happy Valley Adventure Bureau for a special event focused on agritourism in concert with Millheim Borough. If successful, the event would connect Millheim Borough and Ferguson Township establishments including 814 Cider Works and Pine Grove Hall. The resolution also authorizes a local match up to \$4,500 that would come from the Township's Economic Development account.

Pastor Paul Tomkiel gave a PowerPoint presentation on Route 45 Getaways. The project will create an auto trail event for tourists that will connect them with businesses and encourage them to stay overnight. The customers would be hometown tourists and people from nearby metropolitan areas. Ten miles will be used to define the distance for the Route 45 corridor. For tourists the event would provide information on destinations and deals along the trail; especially during 2021 and the pandemic it will give confidence to tourists; assist tourists craft an adventure that they will be remembered. As for business, advertising to wider audiences; vouch for the quality to tourists; and organize events that will help them thrive. The advertising strategy for the first year will be devoted 60% locally and 40% regionally and plan to use a range of media from postcards and stickers to targeted online ads. To launch the project, there will be two weekends of music events, one in Millheim and one in Pine Grove Mills. The key partners are Pine Grove Hall, 814 Cidery, Elk Creek Café, and Pisano Winery. The fixed costs include creating the logo, a map, website, and banners with variable costs for advertising, but since it is the main activity it is the largest projected expense. For 2021, the budget is \$19,503 and seeking a tourism grant through the Happy Valley Adventure Bureau and asking \$4,500 from Ferguson Township as a match. Pastor Tomkiel noted that the kind of event is one that fits well with the Pine Grove Mills – Small Area Plan and will nurture

local businesses; increase awareness for tourists; and creates an event to build the village's identity.

Mr. Mitra inquired about the budget. Ms. Grove noted that if they were awarded it can be used over two-years and specifically for advertising the event for all of the entities. Mr. Mitra expressed concerns with the event not being successful due to lack of backup information. Ms. Dininni stated that the idea of a route as a regional destination has been done in Pennsylvania and have been done successfully. Ms. Dininni noted that they are starting small, but the vision is to be larger across the three counties to be based on agriculture, local food, and outdoor recreation.

Ms. Strickland stated that this year is particularly inviting due to the lack of traditional summer events due to the pandemic. It also diversifies the economy and creates different tourism options not connected to Penn State.

Ms. Stephens stated that she too also likes the idea and asked if the match funding can come from more than one source. Mr. Pribulka stated that it could.

Ms. Pam Steckler, Ferguson Township Resident, noted there are a lot of artist along Route 45 and asked if anyone has reached out to have open houses during the two weekend events. Ms. Dininni noted the more the better and asked Ms. Steckler if she would be willing to contact people. Ms. Steckler agreed to reach out to a few artists along Route 45 about participating in the events.

Mr. Robert Zeigler, President, Millheim Borough Council, noted that Millheim is much smaller with 900 residents and they do not have the resources to take the lead. Mr. Zeigler stated that partnerships are a good way to apply and receive grants. Ms. Dininni noted that Millheim Borough although not giving funds, they are contributing by in-kind organization of events on the first part of the event. Pastor Tomkiel mentioned it would be great to see Route 45 recognized as a scenic road by the Commonwealth of Pennsylvania.

Ms. Dininni moved that the Board of Supervisors **adopt** the resolution authorizing the Township Manager to submit a Tourism Grant application to the Happy Valley Adventure Bureau for an agritourism event with Millheim Borough. Mr. Miller seconded the motion.

ROLL CALL: Mr. Mitra – Yes: Ms. Stephens – Yes: Ms. Strickland – Yes: Ms. Dininni – Yes: Mr. Miller – Yes

### 3. Board Member Request – Terraced Streetscape District Ordinance Amendment

Ms. Strickland made the request and introduced the resolution that was included in the agenda. Ms. Strickland would like to have a discussion with the Board and then send the ordinance to the Planning Commission to deliberate on some of the issues that have arisen. Ms. Strickland is hopeful that there will be a consultant in place next year to evaluate.

#### Board Discussion

Ms. Dininni stated that she is seeing how well the ordinance matches with the intent of the district and how could it be better aligned. Ms. Dininni would like to review parking since it is in the SALDO and how it is being tied to the square footage instead of the use. Ms. Dininni inquired about district boundary change with preserving the neighborhood and allowing for the narrow corridor to be developed in a more robust way. Mr. Pribulka presented a map of the TSD.

Mr. Miller stated that the Township has two different types of areas. Buckhout to Corl Street has certain uses versus Corl to Blue Course. Mr. Miller asked if the TSD should be extended passed Corl Street.

With regards to incentives, Ms. Strickland would like the Planning Commission to evaluate heights of the buildings, parking, workforce housing, impervious surface, etc.

#### Public Comment

Ms. Steckler, Ferguson Township Resident, stated that she was very involved with the TSD. Originally the TSD was to be blended in with the existing neighborhood; however, that request was not included. Ms. Steckler asked to take in consideration the character of the neighborhood and try to blend within.

Mr. Bill Keough, Ferguson Township Resident, noted there were several issues when the Planning Commission reviewed. The issues were the incentives, Calder Alley, vehicle and pedestrian circulation; density; loading and unloading zone; and the Penn State property College Avenue. Mr. Keough expressed disappointed that the Township didn't move forward with guidance from an outside professional.

Ms. Dininni moved that the Board of Supervisors **refer** its comments on the Terraced Streetscape District to the Planning Commission for review and comment. Ms. Stephens seconded the motion. The motion passed unanimously.

#### 4. Contract 2021-C9, Microsurfacing

Mr. Modricker noted that on Tuesday, March 9, 2021, bids were opened and read aloud for Contract 2021-C9 Microsurfacing for select streets in Ferguson and Harris Townships. This is a co-operative contract that is administered by Ferguson Township. The bid was advertised in the Centre Daily Times and sent out to potential bidders. This contract involves the application of a slurry seal to the roads for pavement preservation. Mr. Modricker recommends that the contract be awarded to Asphalt Paving Systems, Inc. in the amount of \$435,839.52.

Ms. Dininni moved that that Board of Supervisors **award** Contract 2021-C9, Microsurfacing to Asphalt Paving Systems, Inc., in an amount of \$435,839.52. Mr. Mitra seconded the motion. The motion passed unanimously.

#### 5. Contract 2021-C7a, Fuel

Ms. Dininni moved that the Board of Supervisors **award** Contract 2021-C7a, Fuel to Nittany Oil Company in an amount of \$59,239.50. Ms. Stephens seconded the motion. The motion passed unanimously.

#### 6. Contract 2021-C7c, Asphalt and Aggregate

Mr. Mitra moved that the Board of Supervisors **award** Contract 2021-C7c, Asphalt & Aggregate as described in Public Works Director memo dated April 13 for items 1 through 4 (aggregate) to Glenn O. Hawbaker, Inc., in the amount of \$17,800.00 and items 5 through 8 (asphalt) to HRI in the amount of \$64,800.00. Ms. Stephens seconded the motion. The motion passed 4-1 with Ms. Dininni opposing.

## IX. STAFF AND COMMITTEE REPORTS

### 1. COG COMMITTEE REPORTS

- a. Human Resources Committee – Mr. Mitra attended the meeting for Ms. Stephens. The Committee discussed the COG Wage Survey and the hiring of the Administrative Services Manager. Ms. Dininni inquired about the survey and the timeline. Mr. Mitra stated it will be completed this year.

- b. Finance Committee – Mr. Miller reported that the Committee met on April 8, 2021 and discussed the loan application; repurposing the budget documents to make it easier to read; and a brief discussion on the COG formulas. Ms. Dininni asked for clarification regarding the Whitehall loan. Mr. Miller noted that the proposal is to consider approving Option #4 with a condition that initially only authorizing the \$7.8 million from Option 1B and any additional borrowing up to \$9 million would have to be by unanimous approval by the municipalities. Mr. Miller stated that there will be more information at the upcoming COG Finance meeting.
- c. Climate Action & Sustainability Committee – Mr. Mitra reported that the Committee discussed the Community Forum on Climate Planning; Solar Power Purchase Agreement update; Technical Advisory Committee for CAAP Implementation; and the Draft Mission Statement for the COG Climate Action and Sustainability Committee.
- d. Public Safety Committee – Ms. Strickland attended the meeting for Ms. Dininni. There were two presentations given by Mr. Steve Bair that was on Fire Department Organization and Fire Department Strategic Planning.

## 2. STAFF REPORTS

- a. Manager's Report – Mr. Pribulka noted report is included in the agenda. Ms. Strickland asked if there were any other communication regarding the PA Route 26 and 45 with regards to pedestrian accommodations. Mr. Pribulka spoke with the Design Project Manager for District 2 and he noted that it didn't meet any warrants to provide accommodations. Mr. Pribulka asked to have the issue revisited. Mr. Pribulka is hopeful but not optimistic and feels it is a bad idea not to include the accommodations.
- b. Public Works Director - Mr. Pribulka noted that the report is included in the agenda.
- c. Planning and Zoning Director - Mr. Pribulka noted that the report is included in the agenda. Ms. Dininni noted that she attended the Park Authority meeting and from her perception they didn't address the letter the Township sent. Mr. Pribulka stated that they didn't receive acknowledgment of the letter. Mr. Pribulka noted that he met with representatives regarding the land development plan and discussed any proposed changes that may have an impact. Mr. Pribulka commented there wasn't a lot of information to be shared. Mr. Keough stated that there were three different options forwarded to Stahl Schaffer Engineering and the authority has not made a decision.
- d. Chief of Police Report – Mr. Pribulka noted that the report is included in the agenda.

## X. COMMUNICATIONS TO THE BOARD

Ms. Strickland received a communication supporting the Planning Commission of reviewing and discussing the TSD.

Ms. Strickland noted that she attended the Climate Action Forum and it was very well done. Ms. Strickland also attended the Strategies for Justice Symposium on Conscious Law Enforcement & Inclusive Practices.

## XI. CALENDAR ITEMS – APRIL

- a. Ferguson Township upcoming committee meetings:
  - 1. Pine Grove Mills SAP Advisory Committee, Thursdays, April 22 and May 27, 4PM
  - 2. Planning Commission, Monday, April 26, 6PM
  - 3. Board of Supervisors, Mondays, May 3 and May 17, 7PM
  - 4. Planning Commission, Mondays, May 10 and May 24, 6PM
  - 5. Tree Commission, Monday, May 17, 4PM

- 6. Parks & Recreation Committee, Thursday, May 20, 4PM
- b. Watershed Cleanup Day, Saturday, April 24, 8AM – 12PM
- c. Ferguson Township Virtual Bike Chat, Thursday, May 20, 12:30PM

**XII. ADJOURNMENT**

With no further business to come before the Board of Supervisors, Mr. Mitra motioned to adjourn the meeting. The meeting adjourned at 10:25 p.m.

Respectfully submitted,

David Pribulka, Township Manager  
For the Board of Supervisors

DRAFT



## **FERGUSON TOWNSHIP**

### **FIRST QUARTER FINANCIAL REPORT - 2021**

- ❖ BOS REVENUE SUMMARY
- ❖ BOS EXPENDITURE SUMMARY

# General Ledger

## Quarterly BOS Revenue Summary



User: eendresen  
 Printed: 4/29/2021 4:31:06 PM  
 Period 01 - 03  
 Fiscal Year 2021

Account Number	Description	Budget	Current Actual	YTD Actual	\$ Remain	% Remain
<b>01</b>	<b>GENERAL FUND</b>					
301	REAL PROPERTY TAX REVENUE	1,459,527.00	277,399.41	277,399.41	1,182,127.59	80.99
310	LOCAL ENABLING TAX REVENUE	8,400,000.00	2,280,524.51	2,280,524.51	6,119,475.49	72.85
321	BUSINESS LICENSES & PERMITS	265,480.00	63,218.68	63,218.68	202,261.32	76.19
322	NON-BUSINESS LICENSESPERMITS	52,952.00	1,950.00	1,950.00	51,002.00	96.32
331	FINES	55,300.00	8,027.18	8,027.18	47,272.82	85.48
332	FOREFEITS	0.00	0.00	0.00	0.00	0.00
341	INTEREST EARNED	75,700.00	19,563.46	19,563.46	56,136.54	74.16
342	RENTS & ROYALTIES	42,829.00	10,707.13	10,707.13	32,121.87	75.00
351	FEDERAL GRANTS	22,484.00	9,150.74	9,150.74	13,333.26	59.30
354	STATE GRANTS	41,763.00	3,324.63	3,324.63	38,438.37	92.04
355	STATE SHARED REVENUES	573,996.00	0.00	0.00	573,996.00	100.00
356	STATE PAYMENT IN-LIEU OF TAX	7,973.00	0.00	0.00	7,973.00	100.00
357	LOCAL GRANTS	50,000.00	2,147.99	2,147.99	47,852.01	95.70
358	LOCAL SHARED PAYMENTS	37,000.00	10,882.16	10,882.16	26,117.84	70.59
359	LOCAL PAYMENTS IN-LIEU OF TAX	146,779.00	146,483.03	146,483.03	295.97	0.20
361	DEPARTMENTAL EARNINGS	110,600.00	9,038.51	9,038.51	101,561.49	91.83
362	PUBLIC SAFETY	56,675.00	621.00	621.00	56,054.00	98.90
363	PUBLIC WORKS SERVICE REVENUE	0.00	0.00	0.00	0.00	0.00
364	SANITATION REVENUE	0.00	0.00	0.00	0.00	0.00
365	HEALTH SERVICES REVENUE	8,500.00	1,378.88	1,378.88	7,121.12	83.78
367	CULTURERECREATION	0.00	0.00	0.00	0.00	0.00
389	MISCELLANEOUS REVENUE	96,200.00	1,287.00	1,287.00	94,913.00	98.66
392	INTERFUND TRANSFERS IN	22,648.00	0.00	0.00	22,648.00	100.00
395	REFUNDS OF PRIOR YR'S EXPENSES	0.00	0.00	0.00	0.00	0.00
<b>01</b>	<b>GENERAL FUND</b>	<b>11,526,406.00</b>	<b>2,845,704.31</b>	<b>2,845,704.31</b>	<b>8,680,701.69</b>	<b>75.31</b>
<b>02</b>	<b>STREET LIGHT FUND</b>					
341	INTEREST EARNED	150.00	24.40	24.40	125.60	83.73
383	SPECIAL ASSESSMENTS	21,482.00	0.00	0.00	21,482.00	100.00
392	INTERFUND TRANSFERS IN	0.00	0.00	0.00	0.00	0.00
<b>02</b>	<b>STREET LIGHT FUND</b>	<b>21,632.00</b>	<b>24.40</b>	<b>24.40</b>	<b>21,607.60</b>	<b>99.89</b>
<b>03</b>	<b>HYDRANT FUND</b>					
341	INTEREST EARNED	500.00	100.51	100.51	399.49	79.90
383	SPECIAL ASSESSMENTS	133,333.00	40,000.00	40,000.00	93,333.00	70.00



Account Number	Description	Budget	Current Actual	YTD Actual	\$ Remain	% Remain
392	INTERFUND TRANSFERS IN	0.00	0.00	0.00	0.00	0.00
<b>03</b>	<b>HYDRANT FUND</b>	<b>133,833.00</b>	<b>40,100.51</b>	<b>40,100.51</b>	<b>93,732.49</b>	<b>70.04</b>
<b>16</b>	<b>GOA FUND</b>					
341	INTEREST EARNED	10,000.00	5,691.82	5,691.82	4,308.18	43.08
389	MISCELLANEOUS REVENUE	0.00	0.00	0.00	0.00	0.00
392	INTERFUND TRANSFERS IN	400,000.00	0.00	0.00	400,000.00	100.00
393	PROCEEDS FROM LONG TERM DEBT	0.00	0.00	0.00	0.00	0.00
<b>16</b>	<b>GOA FUND</b>	<b>410,000.00</b>	<b>5,691.82</b>	<b>5,691.82</b>	<b>404,308.18</b>	<b>98.61</b>
<b>19</b>	<b>AG PRESERVATION FUND</b>					
341	INTEREST EARNED	750.00	45.44	45.44	704.56	93.94
392	INTERFUND TRANSFERS IN	0.00	0.00	0.00	0.00	0.00
<b>19</b>	<b>AG PRESERVATION FUND</b>	<b>750.00</b>	<b>45.44</b>	<b>45.44</b>	<b>704.56</b>	<b>93.94</b>
<b>20</b>	<b>STORMWATER FUND</b>					
341	INTEREST EARNED	100.00	141.90	141.90	-41.90	-41.90
354	STATE GRANTS	0.00	0.00	0.00	0.00	0.00
357	LOCAL GRANTS	0.00	0.00	0.00	0.00	0.00
383	SPECIAL ASSESSMENTS	0.00	0.00	0.00	0.00	0.00
389	MISCELLANEOUS REVENUE	0.00	0.00	0.00	0.00	0.00
392	INTERFUND TRANSFERS IN	1,221,000.00	200,000.00	200,000.00	1,021,000.00	83.62
<b>20</b>	<b>STORMWATER FUND</b>	<b>1,221,100.00</b>	<b>200,141.90</b>	<b>200,141.90</b>	<b>1,020,958.10</b>	<b>83.61</b>
<b>30</b>	<b>CAPITAL RESERVE FUND</b>					
341	INTEREST EARNED	22,500.00	3,588.97	3,588.97	18,911.03	84.05
342	RENTS & ROYALTIES	10,000.00	0.00	0.00	10,000.00	100.00
354	STATE GRANTS	272,800.00	0.00	0.00	272,800.00	100.00
355	STATE SHARED REVENUES	0.00	0.00	0.00	0.00	0.00
357	LOCAL GRANTS	0.00	0.00	0.00	0.00	0.00
358	LOCAL SHARED PAYMENTS	0.00	0.00	0.00	0.00	0.00
387	PRIVATE CONTRIBUTIONS	0.00	0.00	0.00	0.00	0.00
389	MISCELLANEOUS REVENUE	0.00	0.00	0.00	0.00	0.00
391	SALE OF FIXED ASSETS	2,000.00	0.00	0.00	2,000.00	100.00
392	INTERFUND TRANSFERS IN	1,917,400.00	2,182,689.38	2,182,689.38	-265,289.38	-13.84
<b>30</b>	<b>CAPITAL RESERVE FUND</b>	<b>2,224,700.00</b>	<b>2,186,278.35</b>	<b>2,186,278.35</b>	<b>38,421.65</b>	<b>1.73</b>
<b>31</b>	<b>REG CAP REC PROJECTS FUND</b>					
341	INTEREST EARNED	15,000.00	2,713.58	2,713.58	12,286.42	81.91
387	PRIVATE CONTRIBUTIONS	0.00	0.00	0.00	0.00	0.00
389	MISCELLANEOUS REVENUE	0.00	0.00	0.00	0.00	0.00
392	INTERFUND TRANSFERS IN	0.00	0.00	0.00	0.00	0.00
<b>31</b>	<b>REG CAP REC PROJECTS FUND</b>	<b>15,000.00</b>	<b>2,713.58</b>	<b>2,713.58</b>	<b>12,286.42</b>	<b>81.91</b>
<b>32</b>	<b>TRANSPORT IMPROVEMENT FUND</b>					
341	INTEREST EARNED	50,000.00	5,228.98	5,228.98	44,771.02	89.54
351	FEDERAL GRANTS	606,900.00	0.00	0.00	606,900.00	100.00
354	STATE GRANTS	0.00	0.00	0.00	0.00	0.00

Account Number	Description	Budget	Current Actual	YTD Actual	\$ Remain	% Remain
357	LOCAL GRANTS	0.00	0.00	0.00	0.00	0.00
387	PRIVATE CONTRIBUTIONS	0.00	0.00	0.00	0.00	0.00
389	MISCELLANEOUS REVENUE	0.00	0.00	0.00	0.00	0.00
392	INTERFUND TRANSFERS IN	1,093,397.00	1,290.32	1,290.32	1,092,106.68	99.88
<b>32</b>	<b>TRANSPORT IMPROVEMENT FUND</b>	<b>1,750,297.00</b>	<b>6,519.30</b>	<b>6,519.30</b>	<b>1,743,777.70</b>	<b>99.63</b>
<b>33</b>	<b>PGM STREETLIGHT FUND</b>					
341	INTEREST EARNED	300.00	48.96	48.96	251.04	83.68
387	PRIVATE CONTRIBUTIONS	0.00	0.00	0.00	0.00	0.00
392	INTERFUND TRANSFERS IN	0.00	0.00	0.00	0.00	0.00
<b>33</b>	<b>PGM STREETLIGHT FUND</b>	<b>300.00</b>	<b>48.96</b>	<b>48.96</b>	<b>251.04</b>	<b>83.68</b>
<b>34</b>	<b>PARK IMPROVEMENT FUND</b>					
341	INTEREST EARNED	2,000.00	228.95	228.95	1,771.05	88.55
354	STATE GRANTS	250,000.00	0.00	0.00	250,000.00	100.00
359	LOCAL PAYMENTS IN-LIEU OF TAX	0.00	0.00	0.00	0.00	0.00
367	CULTURERECREATION	0.00	0.00	0.00	0.00	0.00
387	PRIVATE CONTRIBUTIONS	126,000.00	0.00	0.00	126,000.00	100.00
389	MISCELLANEOUS REVENUE	0.00	0.00	0.00	0.00	0.00
392	INTERFUND TRANSFERS IN	360,000.00	0.00	0.00	360,000.00	100.00
<b>34</b>	<b>PARK IMPROVEMENT FUND</b>	<b>738,000.00</b>	<b>228.95</b>	<b>228.95</b>	<b>737,771.05</b>	<b>99.97</b>
<b>35</b>	<b>LIQUID FUELS FUND</b>					
341	INTEREST EARNED	20,000.00	541.53	541.53	19,458.47	97.29
355	STATE SHARED REVENUES	601,872.00	618,646.21	618,646.21	-16,774.21	-2.79
392	INTERFUND TRANSFERS IN	50,000.00	0.00	0.00	50,000.00	100.00
<b>35</b>	<b>LIQUID FUELS FUND</b>	<b>671,872.00</b>	<b>619,187.74</b>	<b>619,187.74</b>	<b>52,684.26</b>	<b>7.84</b>
<i>Revenue Total</i>		<u><b>18,713,890.00</b></u>	<u><b>5,906,685.26</b></u>	<u><b>5,906,685.26</b></u>	<u><b>12,807,204.74</b></u>	<u><b>0.6844</b></u>

# General Ledger

## Quarterly BOS

### Expenditure Summary



User: eendresen  
 Printed: 4/29/2021 4:32:43 PM  
 Period 01 - 03  
 Fiscal Year 2021

Account Number	Description	Budget	Current Actual	YTD Actual	Encumbered	\$ Remain	% Remain
<b>01</b>	<b>GENERAL FUND</b>						
400	LEGISLATIVE BODY	60,198.00	7,107.78	7,107.78	0.00	53,090.22	88.19
401	EXECUTIVE	378,553.00	82,763.11	82,763.11	0.00	295,789.89	78.14
402	FINANCE	241,179.00	54,566.13	54,566.13	0.00	186,612.87	77.38
403	TAX OFFICE	48,425.00	15,924.01	15,924.01	0.00	32,500.99	67.12
404	LEGAL	80,000.00	8,054.08	8,054.08	0.00	71,945.92	89.93
406	OTHER GOVT ADMINISTRATION	130,739.00	32,684.75	32,684.75	0.00	98,054.25	75.00
407	IT-NETWORKING	189,498.00	65,991.08	65,991.08	0.00	123,506.92	65.18
408	ENGINEERING	384,964.00	87,371.60	87,371.60	0.00	297,592.40	77.30
409	BUILDINGS & GROUNDS	193,960.00	50,049.46	50,049.46	3,405.00	140,505.54	72.44
410	POLICE	2,602,689.00	523,417.45	523,417.45	20,999.23	2,058,272.32	79.08
411	FIRE	568,784.00	108,475.00	108,475.00	0.00	460,309.00	80.93
412	AMBULANCE	6,500.00	0.00	0.00	0.00	6,500.00	100.00
413	CODE ENFORCEMENT	300.00	0.00	0.00	0.00	300.00	100.00
414	PLANNING & ZONING	453,693.00	98,948.97	98,948.97	0.00	354,744.03	78.19
415	EMERGENCY MANAGEMENT	37,299.00	9,324.75	9,324.75	0.00	27,974.25	75.00
421	HEALTH & WELFARE	8,500.00	1,043.20	1,043.20	0.00	7,456.80	87.73
426	RECYCLING	33,005.00	0.00	0.00	0.00	33,005.00	100.00
430	PUBLIC WORKS ADMINISTRATION	114,511.00	39,741.32	39,741.32	3,271.00	71,498.68	62.44
432	WINTER MAINTENANCE	21,300.00	18,326.28	18,326.28	0.00	2,973.72	13.96
433	TRAFFIC CONTROL DEVICES	46,000.00	4,319.42	4,319.42	3,082.00	38,598.58	83.91
437	TOOLS & EQUIPMENT MAINTENANCE	223,539.00	47,367.04	47,367.04	0.00	176,171.96	78.81
438	ROAD & BRIDGE MAINTENANCE	713,784.00	159,301.41	159,301.41	0.00	554,482.59	77.68
447	TRANSIT SYSTEM	133,638.00	33,877.50	33,877.50	0.00	99,760.50	74.65
452	PARTICIPANT RECREATION	726,388.00	178,225.75	178,225.75	0.00	548,162.25	75.46
453	SPECTATOR RECREATION	6,000.00	500.00	500.00	0.00	5,500.00	91.67
454	PARKS	0.00	0.00	0.00	0.00	0.00	0.00
455	SHADE TREES	159,505.00	20,051.14	20,051.14	0.00	139,453.86	87.43
456	LIBRARIES	499,667.00	124,916.75	124,916.75	0.00	374,750.25	75.00
458	SENIOR CITIZENS	36,258.00	9,064.50	9,064.50	0.00	27,193.50	75.00
461	NATURAL RESOURCE CONSERVATION	6,609.00	0.00	0.00	0.00	6,609.00	100.00
462	SLAB CABIN RUN INITIATIVE	5,000.00	0.00	0.00	0.00	5,000.00	100.00
463	COMMUNITY DEVELOPMENT	15,000.00	0.00	0.00	0.00	15,000.00	100.00
472	DEBT SERVICE INTEREST	2,000.00	0.00	0.00	0.00	2,000.00	100.00

Account Number	Description	Budget	Current Actual	YTD Actual	Encumbered	\$ Remain	% Remain
481	PAYROLL TAXES	330,500.00	75,368.71	75,368.71	0.00	255,131.29	77.20
483	PENSIONS	607,878.00	45,773.14	45,773.14	0.00	562,104.86	92.47
486	PROPERTY INSURANCE	246,100.00	139,759.00	139,759.00	2,785.00	103,556.00	42.08
487	HEALTH INSURANCE	1,084,500.00	160,959.05	160,959.05	0.00	923,540.95	85.16
489	MISCELLANEOUS EXPENSE	52,776.00	3,510.00	3,510.00	0.00	49,266.00	93.35
491	REFUND OF PRIOR YR'S REVENUE	0.00	0.00	0.00	0.00	0.00	0.00
492	INTERFUND TRANSFERS OUT	2,549,397.00	346,212.50	346,212.50	0.00	2,203,184.50	86.42
<b>01</b>	<b>GENERAL FUND</b>	<b>12,998,636.00</b>	<b>2,552,994.88</b>	<b>2,552,994.88</b>	<b>33,542.23</b>	<b>10,412,098.89</b>	<b>80.10</b>
<b>02</b>	<b>STREET LIGHT FUND</b>						
434	STREET LIGHTING	19,500.00	221.80	221.80	0.00	19,278.20	98.86
<b>02</b>	<b>STREET LIGHT FUND</b>	<b>19,500.00</b>	<b>221.80</b>	<b>221.80</b>	<b>0.00</b>	<b>19,278.20</b>	<b>98.86</b>
<b>03</b>	<b>HYDRANT FUND</b>						
448	WATER SYSTEMS	118,528.00	27,132.00	27,132.00	0.00	91,396.00	77.11
<b>03</b>	<b>HYDRANT FUND</b>	<b>118,528.00</b>	<b>27,132.00</b>	<b>27,132.00</b>	<b>0.00</b>	<b>91,396.00</b>	<b>77.11</b>
<b>16</b>	<b>GOA FUND</b>						
401	EXECUTIVE	500.00	0.00	0.00	0.00	500.00	100.00
404	LEGAL	0.00	0.00	0.00	0.00	0.00	0.00
471	DEBT SERVICE PRINCIPAL	105,000.00	0.00	0.00	0.00	105,000.00	100.00
472	DEBT SERVICE INTEREST	178,468.00	0.00	0.00	0.00	178,468.00	100.00
475	FISCAL AGENT FEES	0.00	0.00	0.00	0.00	0.00	0.00
486	PROPERTY INSURANCE	0.00	0.00	0.00	0.00	0.00	0.00
492	INTERFUND TRANSFERS OUT	1,867,400.00	2,182,689.38	2,182,689.38	0.00	-315,289.38	-16.88
<b>16</b>	<b>GOA FUND</b>	<b>2,151,368.00</b>	<b>2,182,689.38</b>	<b>2,182,689.38</b>	<b>0.00</b>	<b>-31,321.38</b>	<b>-1.46</b>
<b>18</b>	<b>CLOSED DO NOT USE</b>						
439	ROAD CONSTRUCTION	0.00	0.00	0.00	0.00	0.00	0.00
492	INTERFUND TRANSFERS OUT	0.00	0.00	0.00	0.00	0.00	0.00
<b>18</b>	<b>CLOSED DO NOT USE</b>	<b>0.00</b>	<b>0.00</b>	<b>0.00</b>	<b>0.00</b>	<b>0.00</b>	<b>0.00</b>
<b>19</b>	<b>AG PRESERVATION FUND</b>						
461	NATURAL RESOURCE CONSERVATION	0.00	0.00	0.00	0.00	0.00	0.00
<b>19</b>	<b>AG PRESERVATION FUND</b>	<b>0.00</b>	<b>0.00</b>	<b>0.00</b>	<b>0.00</b>	<b>0.00</b>	<b>0.00</b>
<b>20</b>	<b>STORMWATER FUND</b>						
402	FINANCE	0.00	0.00	0.00	0.00	0.00	0.00
404	LEGAL	0.00	0.00	0.00	0.00	0.00	0.00
408	ENGINEERING	376,341.00	11,048.46	11,048.46	0.00	365,292.54	97.06
434	STREET LIGHTING	0.00	0.00	0.00	0.00	0.00	0.00
439	ROAD CONSTRUCTION	0.00	0.00	0.00	0.00	0.00	0.00
446	STORMWATER	794,812.00	27,809.41	27,809.41	0.00	767,002.59	96.50
<b>20</b>	<b>STORMWATER FUND</b>	<b>1,171,153.00</b>	<b>38,857.87</b>	<b>38,857.87</b>	<b>0.00</b>	<b>1,132,295.13</b>	<b>96.68</b>
<b>30</b>	<b>CAPITAL RESERVE FUND</b>						
401	EXECUTIVE	20,000.00	0.00	0.00	0.00	20,000.00	100.00

Account Number	Description	Budget	Current Actual	YTD Actual	Encumbered	\$ Remain	% Remain
402	FINANCE	0.00	0.00	0.00	0.00	0.00	0.00
407	IT-NETWORKING	36,250.00	0.00	0.00	0.00	36,250.00	100.00
408	ENGINEERING	0.00	0.00	0.00	0.00	0.00	0.00
409	BUILDINGS & GROUNDS	1,969,785.00	1,994,626.24	1,994,626.24	13,260.00	-38,101.24	-1.93
410	POLICE	143,500.00	46,193.75	46,193.75	0.00	97,306.25	67.81
414	PLANNING & ZONING	0.00	0.00	0.00	0.00	0.00	0.00
430	PUBLIC WORKS ADMINISTRATION	611,091.00	7,601.00	7,601.00	138,457.40	465,032.60	76.10
434	STREET LIGHTING	32,000.00	0.00	0.00	0.00	32,000.00	100.00
438	ROAD & BRIDGE MAINTENANCE	0.00	0.00	0.00	0.00	0.00	0.00
439	ROAD CONSTRUCTION	0.00	0.00	0.00	0.00	0.00	0.00
446	STORMWATER	0.00	1,807.50	1,807.50	0.00	-1,807.50	0.00
452	PARTICIPANT RECREATION	0.00	0.00	0.00	0.00	0.00	0.00
454	PARKS	0.00	0.00	0.00	0.00	0.00	0.00
455	SHADE TREES	9,450.00	4,218.85	4,218.85	0.00	5,231.15	55.36
486	PROPERTY INSURANCE	6,000.00	1,367.97	1,367.97	0.00	4,632.03	77.20
492	INTERFUND TRANSFERS OUT	0.00	0.00	0.00	0.00	0.00	0.00
<b>30</b>	<b>CAPITAL RESERVE FUND</b>	<b>2,828,076.00</b>	<b>2,055,815.31</b>	<b>2,055,815.31</b>	<b>151,717.40</b>	<b>620,543.29</b>	<b>21.94</b>
<b>31</b>	<b>REG CAP REC PROJECTS FUND</b>						
439	ROAD CONSTRUCTION	0.00	0.00	0.00	0.00	0.00	0.00
452	PARTICIPANT RECREATION	146,819.00	26,614.75	26,614.75	0.00	120,204.25	81.87
492	INTERFUND TRANSFERS OUT	285,000.00	0.00	0.00	0.00	285,000.00	100.00
<b>31</b>	<b>REG CAP REC PROJECTS FUND</b>	<b>431,819.00</b>	<b>26,614.75</b>	<b>26,614.75</b>	<b>0.00</b>	<b>405,204.25</b>	<b>93.84</b>
<b>32</b>	<b>TRANSPORT IMPROVEMENT FUND</b>						
402	FINANCE	0.00	0.00	0.00	0.00	0.00	0.00
404	LEGAL	0.00	0.00	0.00	0.00	0.00	0.00
408	ENGINEERING	113,000.00	10,144.63	10,144.63	0.00	102,855.37	91.02
434	STREET LIGHTING	101,000.00	1,200.00	1,200.00	0.00	99,800.00	98.81
439	ROAD CONSTRUCTION	1,559,900.00	362,296.20	362,296.20	0.00	1,197,603.80	76.77
492	INTERFUND TRANSFERS OUT	340,000.00	0.00	0.00	0.00	340,000.00	100.00
<b>32</b>	<b>TRANSPORT IMPROVEMENT FUND</b>	<b>2,113,900.00</b>	<b>373,640.83</b>	<b>373,640.83</b>	<b>0.00</b>	<b>1,740,259.17</b>	<b>82.32</b>
<b>33</b>	<b>PGM STREETLIGHT FUND</b>						
434	STREET LIGHTING	0.00	0.00	0.00	0.00	0.00	0.00
439	ROAD CONSTRUCTION	0.00	0.00	0.00	0.00	0.00	0.00
<b>33</b>	<b>PGM STREETLIGHT FUND</b>	<b>0.00</b>	<b>0.00</b>	<b>0.00</b>	<b>0.00</b>	<b>0.00</b>	<b>0.00</b>
<b>34</b>	<b>PARK IMPROVEMENT FUND</b>						
430	PUBLIC WORKS ADMINISTRATION	0.00	0.00	0.00	0.00	0.00	0.00
454	PARKS	867,000.00	59,731.82	59,731.82	2,520.00	804,748.18	92.82
<b>34</b>	<b>PARK IMPROVEMENT FUND</b>	<b>867,000.00</b>	<b>59,731.82</b>	<b>59,731.82</b>	<b>2,520.00</b>	<b>804,748.18</b>	<b>92.82</b>
<b>35</b>	<b>LIQUID FUELS FUND</b>						
404	LEGAL	0.00	0.00	0.00	0.00	0.00	0.00
408	ENGINEERING	0.00	0.00	0.00	0.00	0.00	0.00

<u>Account Number</u>	<u>Description</u>	<u>Budget</u>	<u>Current Actual</u>	<u>YTD Actual</u>	<u>Encumbered</u>	<u>\$ Remain</u>	<u>% Remain</u>
430	PUBLIC WORKS ADMINISTRATION	121,700.00	0.00	0.00	0.00	121,700.00	100.00
432	WINTER MAINTENANCE	122,750.00	96,263.59	96,263.59	0.00	26,486.41	21.58
433	TRAFFIC CONTROL DEVICES	109,000.00	-7,755.87	-7,755.87	0.00	116,755.87	107.12
438	ROAD & BRIDGE MAINTENANCE	284,000.00	1,441.91	1,441.91	0.00	282,558.09	99.49
439	ROAD CONSTRUCTION	95,000.00	0.00	0.00	0.00	95,000.00	100.00
492	INTERFUND TRANSFERS OUT	0.00	0.00	0.00	0.00	0.00	0.00
<b>35</b>	<b>LIQUID FUELS FUND</b>	<b>732,450.00</b>	<b>89,949.63</b>	<b>89,949.63</b>	<b>0.00</b>	<b>642,500.37</b>	<b>87.72</b>
<b>Expense Total</b>		<b><u>23,432,430.00</u></b>	<b><u>7,407,648.27</u></b>	<b><u>7,407,648.27</u></b>	<b><u>187,779.63</u></b>	<b><u>15,837,002.10</u></b>	<b><u>0.6759</u></b>



Township of

FERGUSON

Pennsylvania

# Proclamation

## FERGUSON TOWNSHIP PUBLIC WORKS WEEK MAY 16 – MAY 22, 2021

*Whereas*, public works infrastructure, facilities and services are of vital importance to the health, safety and well-being of the people of this nation; and

*Whereas*, such facilities and services could not be provided without the dedicated efforts of public works professionals, employees, and administrators, representing all levels of government, who are responsible for and must design, build, operate, and maintain the transportation, water supply, wastewater systems, public buildings, and other structures and facilities essential to serve our citizens; and

*Whereas*, it is in the public interest for the citizens and civic leaders of this country to gain knowledge of and to maintain a progressive interest in the public works needs and programs of their respective communities; and

*Whereas*, the American Public Works Association has designated the week of May 16 to May 22 to be National Public Works Week and announced the theme of “*Stronger Together*” to challenge municipalities and their residents to “think about their communities as a symphony of essential services, working in concert to create a great place to live.”

*Now, therefore*, the Ferguson Township Board of Supervisors, does hereby designate the week of May 16-22, 2021, as National Public Works Week in Ferguson Township; and urges all Township residents to join with the Township Board of Supervisors in recognizing the substantial contributions Public Works personnel have made to our national health and welfare.

**PROCLAIMED this 3<sup>th</sup> day of May 2021.**

Ferguson Township Board of Supervisors,

---

Laura Dininni, Chair



Township of

FERGUSON

Pennsylvania

# Proclamation

## 2021 EMERGENCY MEDICAL SERVICES WEEK PROCLAMATION

*Whereas*, Emergency Medical Services is a vital public service; and

*Whereas*, the members of the Emergency Medical Services teams are ready to provide lifesaving care to those in need 24 hours-per-day, seven days-per-week; and

*Whereas*, access to quality emergency care dramatically improves the survival and recovery rate of those who experience sudden illness or injury; and

*Whereas*, emergency medical services systems consist of first responders, emergency medical technicians, paramedics, emergency medical dispatchers, firefighters, police officers, educators, administrators, pre-hospital nurses, emergency nurses, emergency physicians, trained members of the public, and other out-of-hospital medical care providers; and

*Whereas*, the members of Emergency Medical Services teams, whether career or volunteer, engage in thousands of hours of specialized training and continuing education to enhance their lifesaving skills; and

*Whereas*, it is appropriate to recognize the value and the accomplishments of Emergency Medical Services providers by designating an Emergency Medical Services Week.

*Now, therefore*, the Ferguson Township Board of Supervisors does hereby proclaim the week of May 16<sup>th</sup> to May 22<sup>nd</sup> to be Emergency Medical Services Week in Ferguson Township. With the EMS Strong theme, "*This is EMS: Caring for Our Communities*," the Board hereby encourages the community to observe the week with appropriate programs, ceremonies, and activities.

**Proclaimed this 3<sup>rd</sup> day of May 2021.**

Ferguson Township Board of Supervisors,

---

Laura Dininni, Chair



ORDINANCE NO. \_\_\_\_\_

**AN ORDINANCE OF THE TOWNSHIP OF FERGUSON, CENTRE COUNTY, PENNSYLVANIA, AMENDING CHAPTER 27, ZONING; PART 3, RESIDENTIAL PLANNED DEVELOPMENT AND MIXED USE; SECTION 304, TERRACED STREETScape (TS) DISTRICT BY AMENDING §27-304.3.B.2. BUILDING HEIGHT INCENTIVES AND REPEALING IT IN ITS ENTIRETY.**

The Board of Supervisors of the Township of Ferguson hereby ordains:

**Section 1**—Chapter 27, Zoning, Part 3, Residential Planned Development and Mixed Use, Section 304, Terraced Streetscape (TS) District by amending §27-304.3.B.(2) Building Height Incentives, is hereby amended repealing it is its entirety:

(2) If structured parking is provided to accommodate the use(s) on the lot and provides space for use by others, an additional 20 feet may be added to the permitted maximum without the need to obtain conditional use approval.

**Section 3**—The forgoing Section 1 shall be effective immediately upon the date of the enactment of this ordinance.

**ORDAINED and ENACTED** this 3<sup>rd</sup> day of May, 2021.

**TOWNSHIP OF FERGUSON**

By: \_\_\_\_\_  
Laura Dininni, Chair  
Board of Supervisors

[ S E A L ]

ATTEST:

By: \_\_\_\_\_  
David G. Pribulka, Secretary



CENTRE COUNTY  
P E N N S Y L V A N I A  
PLANNING AND COMMUNITY  
DEVELOPMENT OFFICE

**BOARD OF COMMISSIONERS**

MICHAEL PIPE, *Chair*  
MARK HIGGINS  
STEVEN G. DERSHEM

Willowbank Office Building  
420 Holmes Street  
Bellefonte, Pennsylvania 16823-1488  
Telephone (814) 355-6791  
FAX (814) 355-8661  
www.centrecountypa.gov

**DIRECTOR**  
RAYMOND J. STOLINAS, JR., AICP

**ASSISTANT DIRECTOR**  
ELIZABETH A. LOSE

April 9, 2021

Ferguson Township Planning & Zoning Department  
Attn: Kristina Aneckstein, Community Planner  
3147 Research Drive  
State College, PA 16801

Re: **Proposed Zoning Ordinance Amendment – Chapter 27 §304.3.B.2., Building Height Incentives**  
*County Planning & Community Development Office Review*

Dear Kristina:

The Centre County Planning and Community Development Office appreciates the opportunity to review the proposed Zoning Ordinance Amendment for Ferguson Township regarding the revisions to the ***Terraced Streetscape (TS) District***, specifically under *Building Height Incentives*. On March 16, 2021, this office received your letter requesting our review of the proposed draft Zoning Ordinance Amendment. The email did not indicate a future Board of Supervisors hearing date for further consideration of the proposed amendment. Pursuant to **§ 609 (e)** of the Pennsylvania Municipalities Planning Code:

***“the county planning agency shall receive a copy of the proposed municipal zoning amendment for recommendations, thirty days (30) prior to public hearing on an amendment by the local governing body, the municipality shall submit the amendment to the county planning agency for recommendations.”***

Moreover, as your municipality considers amending the existing zoning ordinance and map, **§ 609 - Enactment of Zoning Ordinance Amendments** should be followed as a guide towards properly amending the document. Current case law suggests that any deviation from properly amending a zoning ordinance may cause the ordinance to be referred to as “void ab initio” or, in other words, not effective.

Our staff reviewed the proposal and offers the following comments:

**1. REVIEW REQUESTED BY:**

Kristina Aneckstein, Ferguson Township Community Planner

**2. LOCATION:**

N/A

**3. CURRENT/PROPOSED ZONING:**

Ferguson Township Zoning Ordinance, **§27-304. Terraced Streetscape (TS) District**, “intends to encourage innovation and promotes flexibility, economy, and ingenuity in development within the TS District for the purpose of allowing for an increase in the permissible density or intensity of a particular use” (**§27-304.1**). Further, this section outlines design objectives and goals related to parking facilities that create a “park once” approach serving retail and residential development, in addition to promoting development with distinctive architectural elements and siting criteria, creating community character (**27-304.1. B. & E.**).

**4. BACKGROUND:**

Considering the current requirements under **Chapter 27 §304.3.B. Building Height Incentives**, applicants may receive additional building height where shared or structured parking or workforce and age-restricted units are proposed with a particular project. Further, Ferguson Township intends to repeal **Chapter 27 §304.3.B.2**, where provided structured parking accommodating the use on the lot and space for use by others, adding 20 additional feet of building height through the conditional use process.

**5. ADJACENT USES:**

N/A

**6. COMMENTS AND RECOMMENDATIONS:**

The Ferguson Township Board of Supervisors **may** accept the following recommendations related to the proposed zoning ordinance amendment:

- A) The *PA Municipalities Code (MPC)*, under **§603 (c) (2)** allows for “provisions for increases in permissible density or intensity for a particular use based on express standards and criteria set forth in the Zoning Ordinance”. Ferguson Township retains the prerogative of providing, revising and repealing density incentives as outlined within the MPC. **Chapter 27 §304.3.B.** still retains at least one incentive for increasing density by an additional 10’ for providing shared parking facilities on the developing lot. We have no further comment of the proposed amendment repealing **Chapter 27 §304.3.B.2**.

As a reminder, the Pennsylvania Municipalities Planning Code, **§ 609 (g)** specifies that within thirty (30) days after enactment, a copy of the amendment to the zoning ordinance or map shall be forwarded to the county planning agency, if approved by the Ferguson Township Board of Supervisors.

Thank you for allowing our office to review this proposed zoning ordinance amendment in a timely manner. If you require any additional information or have any questions regarding these comments, please contact our office at your earliest convenience.

Sincerely,

A handwritten signature in blue ink, appearing to read "Raymond J. Stolinas Jr." with a stylized flourish at the end.

Raymond J. Stolinas Jr., AICP  
Centre County Planning Director

RJS

cc: Margaret Gray, Centre County Administrator (email)  
Elizabeth Lose, Asst. Planning Director, CCPCDO (email)  
Dave Pribulka, Ferguson Township Manager (email)  
Jenna Wargo, Ferguson Township Planning Director (email)  
file

April 8, 2021

Mr. David Pribulka  
Township Manager  
Ferguson Township  
3147 Research Drive  
State College, PA 16801

**RE: FERGUSON TOWNSHIP – REPEAL OF THE TERRACED STREETScape DISTRICT HEIGHT INCENTIVES - CPRA COMMENTS**

Dear Dave:

The Joint Articles of Agreement of the Centre Regional Planning Commission (CRPC) require that the CRPC review any proposed action of a governing body of a participating municipality relating to:

1. *The location, opening, vacation, extension, narrowing or enlargement of any street, public ground, or watercourse;*
2. *The location, erection, demolition or sale of any public structures located within a municipality;*
3. *The adoption, amendment or repeal of any official map, subdivision and land development ordinance, zoning ordinance or planned residential ordinance.*

This process facilitates regional cooperation and coordination by allowing members of the CRPC to provide advisory comments to the governing body for its consideration. In some instances, such as this, the CRPA Director is authorized to provide comments on behalf of the CRPC. The CRPA has the following comment:

1. The CRPA supports the repeal of height incentives in the Terraced Streetscape District. The intent and spirit of the incentive is to provide both public and private benefit. This has been exploited by a recent development in the Township in such a way as to provide only private benefit. The CRPA suggests that the Board of Supervisors consider repeal an interim action and that mutually beneficial incentives can be crafted in the future to fully implement the vision of the Terraced Streetscape District.

Please call or e-mail if you have questions, or if you require additional information.

Sincerely,

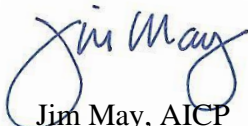

Jim May, AICP  
Director

cc: Jenna Wargo, Director of Planning and Zoning, Ferguson Township  
Corey Rilk, Senior Planner, CRPA  
Centre Regional Planning Commission

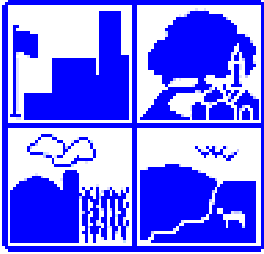

---

# TOWNSHIP OF FERGUSON

3147 Research Drive, State College, Pennsylvania 16801  
Telephone: 814-238-4651 Fax: 814-238-3454

---

TO: Ferguson Township Board of Supervisors

FROM: Kristina Aneckstein  
Community Planner

DATE: April 27, 2021

SUBJECT: Terraced Streetscape Zoning District Ordinance Text Amendment

---

*On March 22, 2021, Planning Commission reviewed the Text Amendment to Terraced Streetscape (TS) Zoning Ordinance, Section 304.3.B.(2). The Planning Commission had no additional comments or suggestion. The Planning Commission recommended the Board of Supervisors to approve the draft to the Board of Supervisors in its current form.*

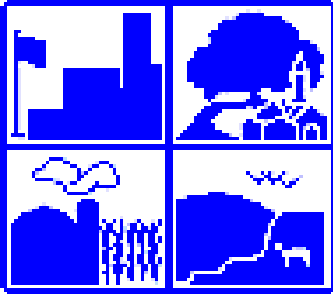

# Ferguson Township

## Donation Request Form

- This form may be completed online and emailed to [dpribulka@twp.ferguson.pa.us](mailto:dpribulka@twp.ferguson.pa.us), or mailed to 3147 Research Drive, State College, PA, 16801. Attention: David Pribulka, Township Manager.
- Please refer to Township website for donation policy: [www.twp.ferguson.pa.us](http://www.twp.ferguson.pa.us)

### ORGANIZATION INFORMATION

Ferguson Township Elementary PTO

Name of Organization: \_\_\_\_\_

Contact Name: Jennifer Heller Contact Number: 610-291-5520

Address: 215 W Pine Grove Rd

City: Pine Grove Mills State: PA Zip Code: 16868

Organization Website: www.ftepto.org Contact Email Address: jheller315@gmail.com

Name of Contact: Jennifer Heller Contact Phone: 610-291-5520

### EVENT OR PROGRAM INFORMATION

Has this organization received a donation from the Township in the past? Yes  No  If yes, when? \_\_\_\_\_

Please identify and list type of requested donation in options described below:

Monetary Amount: \$300 In-kind Goods or Services: \_\_\_\_\_ Township Resources: \_\_\_\_\_

Event or Program Name: Ferguson Township Elementary PTO Fun Run

Date, Time and Place of Event: October 1, 2021 @ Ferguson Township Elementary

Purpose of Program or Event: Annual PTO fundraiser

Description how funds, in-kind donations, or resources will be used: Field trips and school supplies

Targeted area/community the event will serve: Ferguson Township Elementary students and teachers

Additional relevant information: See donation letter

#### Office use only:

Date received: \_\_\_\_\_

Date Donation Request Approved or Denied by Township Manager: \_\_\_\_\_

Township staff name and signature responsible for follow up: \_\_\_\_\_



---

# TOWNSHIP OF FERGUSON

3147 Research Drive • State College, Pennsylvania 16801

Telephone: 814-238-4651 • Fax: 814-238-3454

[www.twp.ferguson.pa.us](http://www.twp.ferguson.pa.us)

---

TO: Ferguson Township Board of Supervisors

FROM: Ronald A. Seybert, Jr., P.E.  
Township Engineer 

DATE: April 23, 2021

SUBJECT: **HARNER 4 LOT SUBDIVISION  
SURETY REDUCTION No. 3**

As requested by Mark Torretti of Penn Terra Engineering, Inc., I have reviewed surety reduction request number 3 for the Harner 4 Lot Subdivision.

The requested reduction is for completion of the sanitary sewer, water, stormwater improvements, and utility conduits onsite.

Based upon a review of the submitted checklist and a site evaluation, I recommend approval of the surety reduction as outlined below.

Current Surety Amount	\$ 1,388,997.34
Amount of Reduction	\$ 536,365.54
<b>Revised Surety Amount</b>	<b>\$ 852,631.79</b>

cc: Harner 4 Lot Subdivision Surety File



**From:** Mitra, Prasenjit <[pmitra@twp.ferguson.pa.us](mailto:pmitra@twp.ferguson.pa.us)>

**Sent:** Monday, April 26, 2021 11:25 PM

**To:** Dininni, Laura <[ldininni@twp.ferguson.pa.us](mailto:ldininni@twp.ferguson.pa.us)>

**Cc:** Pribulka, David <[dpribulka@twp.ferguson.pa.us](mailto:dpribulka@twp.ferguson.pa.us)>

**Subject:** Re: Webinar: How a town used grass to reduce peak water usage by 63% 

Hi David,

Can I request a consent agenda item for the next meeting? Here is some verbiage.

Ferguson Township has a grass/weed ordinance 10.101.1(a) of 6 inches. Lawn mowing caused significant harm to our environment. See: <https://www.onlynaturalenergy.com/grass-lawns-are-an-ecological-catastrophe/> Except in egregious circumstances, there is no evidence of a lawn being a health hazard as mentioned in our ordinance. For example, studies have shown that lawn mowing does not have an effect on the tick population. <https://journals.plos.org/plosone/article?id=10.1371/journal.pone.0214615>

Given the extremely harmful effects of mowing lawns, and the desire by several citizens to be able to keep a more natural lawn, I would request the board to visit the ordinance and repeal or relax the 6 inch requirement.

Thanks,  
Prasenjit

---

# Accounts Payable

## Checks by Date - Detail by Check Number

User: eendresen  
 Printed: 4/27/2021 8:32 AM



Check No	Vendor No Invoice No	Vendor Name Description	Check Date Reference	Void Checks	Check Amount
ACH	10870 030521	PNC INSTITUTIONAL INVESTMENTS POLICE PENSION WITHHELD	03/14/2021		3,546.37
Total for this ACH Check for Vendor 10870:				0.00	3,546.37
ACH	11216 030521	VANTAGEPOINT TRANSFER AGENTS 401	03/14/2021		8,557.52
Total for this ACH Check for Vendor 11216:				0.00	8,557.52
ACH	11218 030521	VANTAGEPOINT TRANSFER AGENTS 457	03/14/2021		7,221.33
Total for this ACH Check for Vendor 11218:				0.00	7,221.33
ACH	11381 030521	VANTAGEPOINT TRANSFER AGENT ROTH IRA	03/14/2021		233.09
Total for this ACH Check for Vendor 11381:				0.00	233.09
ACH	10870 031921 040221	PNC INSTITUTIONAL INVESTMENTS POLICE PENSION WITHHELD POLICE PENSION WITHHELD	03/31/2021		3,546.37 3,546.37
Total for this ACH Check for Vendor 10870:				0.00	7,092.74
ACH	11216 031921 040221	VANTAGEPOINT TRANSFER AGENTS 401 401	03/31/2021	VOID	8,505.71 8,407.48
Total for this ACH Check for Vendor 11216:				16,913.19	0.00
ACH	11218 031921 040221	VANTAGEPOINT TRANSFER AGENTS 457 457	03/31/2021	VOID	6,951.49 6,951.49
Total for this ACH Check for Vendor 11218:				13,902.98	0.00
ACH	11381 031921 040221	VANTAGEPOINT TRANSFER AGENT ROTH IRA ROTH IRA	03/31/2021		233.09 233.09
Total for this ACH Check for Vendor 11381:				0.00	466.18
1	11332 10606 10606	NTM ENGINEERING INC PARK HILLS DRAINAGEWAY RESTORATIO PARK HILLS DRAINAGEWAY RESTORATIO	03/11/2021	VOID	8,803.75 8,803.75
Total for Check Number 1:				17,607.50	0.00
2	11332 10606	NTM ENGINEERING INC PARK HILLS DRAINAGEWAY RESTORATIO	03/11/2021		8,803.75

Check No	Vendor No Invoice No	Vendor Name Description	Check Date Reference	Void Checks	Check Amount
			Total for Check Number 2:	0.00	8,803.75
2	11929 IN1975169	TASC RHS FEES	03/31/2021		75.00
			Total for Check Number 2:	0.00	75.00
6	10231 507612	CLEARFIELD WHOLESALE PAPER CO NEW GARBAGE CANS	03/31/2021		508.93
			Total for Check Number 6:	0.00	508.93
58	11937 2290	WILLOW PLAYWORKS FAIRBROOK PARK PLAYGROUND REPAIR	03/14/2021		12,000.00
			Total for Check Number 58:	0.00	12,000.00
59	11035 A-1869-000-0	STATE COLLEGE BOROUGH WATER A BABE RUTH FIELD WATER	03/31/2021		20.80
			Total for Check Number 59:	0.00	20.80
144	11192 3639-MAR21	WEST PENN POWER HAVASHIRE BLVD LIGHTING	03/31/2021 01.433.036		123.22
			Total for Check Number 144:	0.00	123.22
211	11035 C-1590-159-0	STATE COLLEGE BOROUGH WATER A DOG PARK WATER	03/01/2021		20.80
			Total for Check Number 211:	0.00	20.80
212	11035 C-1590-159-0	STATE COLLEGE BOROUGH WATER A DOG PARK WATER	03/31/2021		20.80
			Total for Check Number 212:	0.00	20.80
395	11228 0673031 0673383 669370	AMERICAN ROCK SALT COMPANY LI BULK ICE CONTROL SALT BULK ICE CONTROL SALT BULK ICE CONTROL SALT	03/14/2021		3,639.27 8,265.27 2,052.77
			Total for Check Number 395:	0.00	13,957.31
396	11228 0674741	AMERICAN ROCK SALT COMPANY LI BULK ICE CONTROL SALT	03/31/2021		4,175.42
			Total for Check Number 396:	0.00	4,175.42
397	10436 770971	GLENN O HAWBAKER INC #3 RIVER GRAVEL	03/31/2021		91.08
			Total for Check Number 397:	0.00	91.08
398	10475 1048150106 3877256	HANSON AGGREGATES PA INC 2A SUBBASE 2A SUBBASE	03/31/2021		533.22 545.91
			Total for Check Number 398:	0.00	1,079.13
839	10031 53994	ALLIED MECHANICAL & ELECTRICA PW BLDG	03/14/2021		121,918.25

Check No	Vendor No Invoice No	Vendor Name Description	Check Date Reference	Void Checks	Check Amount
			Total for Check Number 839:	0.00	121,918.25
840	10236 2102012	CMT LABORATORIES NEW PW BLDG	03/14/2021		860.00
			Total for Check Number 840:	0.00	860.00
841	10955 4355	ROTHROCKS LOCKSMITH MASTERKEY CYLINDER	03/14/2021		944.00
			Total for Check Number 841:	0.00	944.00
842	11262 9373 9398	X-PERT COMMUNICATIONS INSTALL SECURITY CAMERAS IN FT PW B INSTALL DOOR ACCESS CONTROL SYSTEM	03/14/2021		9,936.40 10,355.00
			Total for Check Number 842:	0.00	20,291.40
843	10607 032621	LAKE FORD LINCOLN INC NEW CRUSIER FOR 2021 PER ATTACHED Q	03/30/2021		37,445.00
			Total for Check Number 843:	0.00	37,445.00
844	10031 5	ALLIED MECHANICAL & ELECTRICAL PW BLDG	03/31/2021		339,380.36
			Total for Check Number 844:	0.00	339,380.36
845	11242 1N1H-VH4V-4R9K 1XKX-QNR-7TTQ	AMAZON CAPITAL SERVICES INC 3 PHONES FACE MASK REQUIRED SIGN	03/31/2021		447.00 17.98
			Total for Check Number 845:	0.00	464.98
846	10103 622963	BI LO SUPPLY BLDG #3 SEWER PROJ	03/31/2021		74.21
			Total for Check Number 846:	0.00	74.21
847	10231 507779	CLEARFIELD WHOLESALE PAPER CO. VACUUM/WASTE BASKETS	03/31/2021		609.73
			Total for Check Number 847:	0.00	609.73
848	10644 033121	LOWES COMPANIES INC PRO MIST MAX SPRAY/SPRAY MOP REFILL	03/31/2021		1,382.39
			Total for Check Number 848:	0.00	1,382.39
849	11332 10848	NTM ENGINEERING INC PW BLDG	03/31/2021		643.50
			Total for Check Number 849:	0.00	643.50
850	11033 100433	STATE COLLEGE BATTERY OUTLET BATTERY BACKUPS	03/31/2021		424.00
			Total for Check Number 850:	0.00	424.00
851	11857 40562	TRIANGLE FIRE PROTECTION, INC. 2 NEW SPRINKLER HEADS IN THE BASEM	03/31/2021		1,280.00

Check No	Vendor No Invoice No	Vendor Name Description	Check Date Reference	Void Checks	Check Amount
			Total for Check Number 851:	0.00	1,280.00
852	11165	VIGILANT SECURITY	03/31/2021		
	25168	SYSTEM INSTALL			656.74
	25169	MONITOR/CELL HIGH			126.88
			Total for Check Number 852:	0.00	783.62
853	11880	WHITMAN, REQUARDT & ASSOCIATE	03/31/2021		
	035120.001-12	PW BLDG			4,671.00
	035120.001-13	PW BLDG			12,054.00
	035120.001-14	PW BLDG			24,108.00
			Total for Check Number 853:	0.00	40,833.00
11036	11242	AMAZON CAPITAL SERVICES INC	03/11/2021		
	13KX-PP1T-QR4T	4PK WATERSENTRY PLUS REPLACEMENT			220.50
	1KDY-T7JM-JWQH	LASER LABELS			14.67
	1XD1-PQF4-MPRC	9X12 BROWN ENV			24.98
			Total for Check Number 11036:	0.00	260.15
11037	11702	BLUE KNOB AUTO	03/11/2021		
	030521	UNDERCOVER CAR JAN, FEB AND MARCH			1,050.00
			Total for Check Number 11037:	0.00	1,050.00
11038	10203	CENTRE DAILY TIMES	03/11/2021		
	1866874	BOS MTG FOR ALL BOS MTGS			459.40
	4863745	BOS MTG FEB 23			373.14
	4868332	BOS MTG STORMWATER			196.91
	4870143	SEALED BIDS 2021-C6			330.41
	4872855	BOS MTG2/16			253.17
	4873726	SEALED BIDS 2021-C8			319.73
	4876493	SEALED BIDS 2021-C2			319.73
	4876935	BOS MTG ORD#1066			100.79
	4877219	SEALED BIDS FOR 2021-C9			303.71
			Total for Check Number 11038:	0.00	2,656.99
11039	10374	FEDERAL EXPRESS	03/11/2021		
	1089-1299-5	STND OVRNGHT NOTICE OF VIOLATION F			39.84
			Total for Check Number 11039:	0.00	39.84
11040	11264	GROFF TRACTOR & EQUIPMENT	03/11/2021		
	PSO342349-1	MOTOR/RELAY			520.94
	PSO342992-1	12A-15PSI			25.74
			Total for Check Number 11040:	0.00	546.68
11041	11332	NTM ENGINEERING INC	03/11/2021		
	10607	ES-416			162.25
	10607	ES-1117			243.38
	10607	ES-398			1,865.88
	10607	ES-1107			733.30
	10607	ES-341			1,447.05
	10607	ES-1119			2,109.25
	10728	ES-1107			165.50

Check No	Vendor No Invoice No	Vendor Name Description	Check Date Reference	Void Checks	Check Amount
			Total for Check Number 11041:	0.00	6,726.61
11042	10493 1950070	THE HITE COMPANY SHOP/LAMPS	03/11/2021		116.91
			Total for Check Number 11042:	0.00	116.91
11044	10020 11625	AIKEYS TREE SERVICE TAKE DOWN BLACK LOCUST TREE	03/14/2021		1,475.00
			Total for Check Number 11044:	0.00	1,475.00
11045	10031 155614 156065	ALLIED MECHANICAL & ELECTRICA FIX URNAL IN MENS ROOM FIX URNAL IN MENS ROOM	03/14/2021		117.32 2,078.00
			Total for Check Number 11045:	0.00	2,195.32
11046	10035 043142	ALS TECHNOLOGIES INC BORE THUNDER MUZZLE BANG/EXPULSI	03/14/2021 VOID	1,098.78	
			Total for Check Number 11046:	1,098.78	0.00
11047	10036 020102	ALTOONA MIRROR AD FOR ROAD WORKER	03/14/2021		137.00
			Total for Check Number 11047:	0.00	137.00
11048	11242 1711-6LMW-999X 1MTR-3X11-KQM4 1QDP-M3JK-J9QT	AMAZON CAPITAL SERVICES INC THERMAL RECIEPT PRINTER DIGITAL CLOCK BATTERY FOR TABLET	03/14/2021		250.98 38.87 175.92
			Total for Check Number 11048:	0.00	465.77
11049	11239 91407	ASAP HYDRAULICS STATE COLLEGE, HYDRAULIC MOTOR	03/14/2021		519.19
			Total for Check Number 11049:	0.00	519.19
11050	11649 031621	BABST CALLAND CLEMENTS AND ZC 1st QTR RETAINER	03/14/2021		5,000.00
			Total for Check Number 11050:	0.00	5,000.00
11051	11390 BT1762550	BAKER TILLY VIRCHOW KRAUSE, LL PROGRESS BILLING ON 2020 AUDIT OF CA	03/14/2021		10,000.00
			Total for Check Number 11051:	0.00	10,000.00
11052	10089 012021	JACK A BECK FIX LEAF TRUCK	03/14/2021		300.00
			Total for Check Number 11052:	0.00	300.00
11053	10100 E10231	BEST LINE EQUIPMENT 2 LEAF BLOWERS	03/14/2021		518.00
			Total for Check Number 11053:	0.00	518.00
11054	10122 DUI CHECKPOINT	BOROUGH OF STATE COLLEGE DUI CHECKPOINT 2/27	03/14/2021		678.74

Check No	Vendor No Invoice No	Vendor Name Description	Check Date Reference	Void Checks	Check Amount
		DUI CHECKPOINT	DUI CHECKPOINT 2/4		65.09
			Total for Check Number 11054:	0.00	743.83
11055	10201 030521	CENTRE COUNTY UNITED WAY U WAY	03/14/2021		32.00
			Total for Check Number 11055:	0.00	32.00
11056	10203 4880073	CENTRE DAILY TIMES BOS MTG 0301	03/14/2021		247.38
			Total for Check Number 11056:	0.00	247.38
11057	10225 1902010456	CINTAS CORPORATION # 536 GLOVES	03/14/2021		225.00
			Total for Check Number 11057:	0.00	225.00
11058	11376 022821 022821 022821 022821	COLONIAL AUTO SUPPLY EXHAUST FLUID BRAKE ROTORS/OIL FILTERS WIPER BLADES EXHAUST FLUID	03/14/2021		120.40 265.84 51.68 72.24
			Total for Check Number 11058:	0.00	510.16
11059	10282 2C318672	CUMBERLAND TRUCK EQUIPMENT C ANTIFREEZE	03/14/2021		94.26
			Total for Check Number 11059:	0.00	94.26
11060	10345 1024516	ECKS GARAGE INC FILTER	03/14/2021		46.02
			Total for Check Number 11060:	0.00	46.02
11061	11336 49	F.O.P. LODGE #37 7 EA PA POLICEMAN'S SHORTGUIDE	03/14/2021	VOID	205.00
			Total for Check Number 11061:	205.00	0.00
11062	11217 030521	FERGUSON TOWNSHIP POLICE ASSOC POLICE UNION DUES	03/14/2021		420.00
			Total for Check Number 11062:	0.00	420.00
11063	10396 171-311810 171-311821 171-311970 171-312037 171-312038 171-312045 171-312253 171-312282 171-312282 171-312556 171-312556 171-312557 171-312569 171-312620	FISHER AUTO PARTS OIL FILTER BLADE OIL,GREASE OIL FILTER/LIGHT/PLUG FUEL FILTER OIL BELT WASHER FLUID FILTER/LIGHT/PLUG FILTER WASHER FLUID AIR FILTER AIR FILTER LIGHT	03/14/2021		51.36 14.98 16.74 35.84 2.62 45.40 136.23 29.28 20.80 57.26 24.40 57.26 35.02 33.18

Check No	Vendor No Invoice No	Vendor Name Description	Check Date Reference	Void Checks	Check Amount
	171-312715	AIR FILTERS			105.35
	171-312753	LIGHT			35.22
	171-312784	LIGHT			23.48
	171-312947	WASHER FLUID			63.62
	171-313220	MERITOR			73.97
			Total for Check Number 11063:	0.00	862.01
11064	11483 001-1521302	FORCE AMERICA DISTRIBUTING LLC MOUNTING BITS	03/14/2021		46.49
			Total for Check Number 11064:	0.00	46.49
11065	10492 G400541 G400541	HIRERIGHT SOLUTIONS INC POOL: FERGUSON TOWNSHIP - FMCSA POOL: TOWNSHIP OF FERGUSON - NONDC	03/14/2021	VOID	
				250.00	
				250.00	
			Total for Check Number 11065:	500.00	0.00
11066	11727 X204076113:01 X204076113:02 X204076122:01 X204076122:02 X204076468:01 X204076526:01 X204076678:01	HUNTER TRUCK SALES TENSION BELT/PULLEY PULLEY/ALTERNATOR DRUM BRAKE/REMAN SHOE/SHOE KITS DRUM-BRAKE COVER/CAP DUST SHIELD REMAN SHOE KIT	03/14/2021		
					282.31
					96.78
					118.72
					370.00
					10.37
					99.08
					-70.00
			Total for Check Number 11066:	0.00	907.26
11067	11936 022321	IMSA WORK ZONE TEMP TRAFFIC CONTROL TE	03/14/2021		530.00
			Total for Check Number 11067:	0.00	530.00
11068	11253 7907FEB2021	INFRADAPT LLC INFRADAPT CARRIER SERVICES	03/14/2021		655.78
			Total for Check Number 11068:	0.00	655.78
11069	10568 130582	K & S DISTRIBUTION DIESEL FUEL SUPPLEMENT	03/14/2021		199.80
			Total for Check Number 11069:	0.00	199.80
11070	10618 9308258044	LAWSON PRODUCTS INC HOSE CLAMP	03/14/2021		10.55
			Total for Check Number 11070:	0.00	10.55
11071	10631 030721	DANIEL LEWIS TUITION REIMBURSEMENT LEWIS/APPLIC	03/14/2021		2,935.48
			Total for Check Number 11071:	0.00	2,935.48
11072	10644 031521 031521 031521 031521 031521 031521	LOWES COMPANIES INC PARTS FOR BRINE TANK FINISH NAILER LOCK/PIPE/SCREW/HOSE/PIPE/FIX DOOR STEEL PIECES/PEX RODS	03/14/2021		
					15.63
					502.96
					137.41
					11.27
					13.92
					86.40



Check No	Vendor No Invoice No	Vendor Name Description	Check Date Reference	Void Checks	Check Amount
			Total for Check Number 11072:	0.00	767.59
11073	10673	MCCARTNEYS INC	03/14/2021		
	24370-0	FILE FOLDER			70.11
	25785-0	LABELS			33.99
	25954-0	BLACK STAMP PAD			16.76
	26175-0	TAPE			24.99
	26236-0	PAPER/FOLDER/STAPLER			66.22
			Total for Check Number 11073:	0.00	212.07
11074	11807	MODEL UNIFORMS	03/14/2021		
	1485289	PW UNIF CLN			109.40
			Total for Check Number 11074:	0.00	109.40
11075	10798	PA ONE CALL SYSTEM	03/14/2021		
	896375	MONTHLY ACTIVITY FEE/EMAIL DELIVER			26.28
			Total for Check Number 11075:	0.00	26.28
11076	10845	PENNSYLVANIA MUNICIPAL HEALTH	03/14/2021		
	53207-0	HEALTHCARE INS			69,953.41
	53207-0	DENTAL INS			3,353.82
	53207-0	EYECARE INS			626.96
			Total for Check Number 11076:	0.00	73,934.19
11077	10923	RBA PROFESSIONAL DATA SYSTEMS	03/14/2021		
	210090	2021 MUNI RE TAX/2020 MUNI RE SUPP TA			2,554.81
	210119	2 USERS			300.00
			Total for Check Number 11077:	0.00	2,854.81
11078	10957	ROY BROOKS WELDING INC	03/14/2021		
	1916	STEEL TUBE			77.50
			Total for Check Number 11078:	0.00	77.50
11079	10977	SCHAEDLER YESCO DISTRIBUTION	03/14/2021		
	S6067379.001	BALLAST			100.48
			Total for Check Number 11079:	0.00	100.48
11080	11017	SOSMETAL PRODUCTS INC	03/14/2021		
	1432504	TIRE & TUBE COMPOUND			93.89
			Total for Check Number 11080:	0.00	93.89
11081	11033	STATE COLLEGE BATTERY OUTLET	03/14/2021	VOID	
	100433	BATTERY BACKUPS		424.00	
			Total for Check Number 11081:	424.00	0.00
11082	11058	STOVER MCGLAUGHLIN	03/14/2021		
	148658	REVIEW CIRCLEVILLE PETITION FOR ALL			153.00
			Total for Check Number 11082:	0.00	153.00
11083	11696	STROUSE ELECTRIC INC.	03/14/2021		
	030321-17	REPLACED LIGHT POLE AND HEAD ASSEN			5,690.00

Check No	Vendor No Invoice No	Vendor Name Description	Check Date Reference	Void Checks	Check Amount
			Total for Check Number 11083:	0.00	5,690.00
11084	11887	STUCK ENTERPRISE CO	03/14/2021		
	602871	PW FUEL			1,259.88
	602871	POLICE FUEL			2,939.72
			Total for Check Number 11084:	0.00	4,199.60
11085	11113	TRACTOR SUPPLY CREDIT PLAN	03/14/2021		
	032321	ROD			10.99
			Total for Check Number 11085:	0.00	10.99
11086	11159	VERIZON WIRELESS	03/14/2021		
	9874549763	AIRTIME CARD			40.16
	9874549763	POLICE CELL USE			67.47
	9874549763	POLICE CELL PHONE WITHHOLDING			10.00
	9874549763	CELL PHONE WITHHOLDING			-10.00
	9874549763	PZ & OEO CELL USE			112.48
	9874549763	HOT BOX USE			40.01
	9874549763	ADM CELL USE			42.33
			Total for Check Number 11086:	0.00	302.45
11087	11173	WALKER & WALKER EQUIPMENT II I	03/14/2021	VOID	
	WS02367	FIX EXHAUST VALVE		396.53	
			Total for Check Number 11087:	396.53	0.00
11088	11353	WEAVER WELDING & MFG	03/14/2021		
	7124	PULLEYS			56.85
			Total for Check Number 11088:	0.00	56.85
11089	11199	WILLIAMS BROTHERS	03/14/2021		
	1109355-01	FLAT WASHER/LOCK WASHER/HEX			24.82
			Total for Check Number 11089:	0.00	24.82
11090	11035	STATE COLLEGE BOROUGH WATER A	03/01/2021		
	A-1541-002-0	BUILDING 3 WATER			125.20
			Total for Check Number 11090:	0.00	125.20
11091	11035	STATE COLLEGE BOROUGH WATER A	03/31/2021		
	A-1541-002-0	BUILDING 3 WATER			165.80
			Total for Check Number 11091:	0.00	165.80
11092	10016	AFLAC	03/31/2021		
	040121	INSURANCE WITHHELD			118.17
			Total for Check Number 11092:	0.00	118.17
11093	10035	ALS TECHNOLOGIES INC	03/31/2021		
	043142	BORE THUNDER MUZZLE BANG/EXPULSI			1,098.78
			Total for Check Number 11093:	0.00	1,098.78
11094	11083	AXON ENTERPRISE, INC	03/31/2021		
	SI-1724868	INTERVIEW ROOM UNLIMITED EVIDENCE			12,772.68

Check No	Vendor No Invoice No	Vendor Name Description	Check Date Reference	Void Checks	Check Amount
			Total for Check Number 11094:	0.00	12,772.68
11095	11649 1500237	BABST CALLAND CLEMENTS AND ZC PINE HALL LAND USE APPEALS	03/31/2021		1,050.00
			Total for Check Number 11095:	0.00	1,050.00
11096	10100 E10231 P79794 P79841 R15128	BEST LINE EQUIPMENT STIHL BG 86 SPARK PLUG/AIR FILTER/CAP AIR FILTER RENTAL VAC BASE/WATER TANK	03/31/2021		518.00 57.95 -22.99 155.87
			Total for Check Number 11096:	0.00	708.83
11097	11702 040121	BLUE KNOB AUTO UNDERCOVER VEHICLE	03/31/2021		350.00
			Total for Check Number 11097:	0.00	350.00
11098	10120 032421 032421	BORING COURT REPORTING HEARING FOR TUSSEY TRACKS HEARING FOR TUSSEY TRACKS	03/31/2021		112.50 112.50
			Total for Check Number 11098:	0.00	225.00
11099	10122 030121 030221 030321 030421 030521	BOROUGH OF STATE COLLEGE DUI CHECKPOINT MAR DUI CHECKPOINT MAR DUI CHECKPOINT MAR DUI CHECKPOINT MAR DUI CHECKPOINT MAR	03/31/2021		285.20 455.63 130.18 130.18 608.04
			Total for Check Number 11099:	0.00	1,609.23
11100	10148 34288	CALIBRE PRESS DE-ESCALATION, INTERVENTION AND FO	03/31/2021		1,518.00
			Total for Check Number 11100:	0.00	1,518.00
11101	11885 51228	CDI LASERFICHE ANNUAL SUPPORT & UPDAT	03/31/2021		6,070.00
			Total for Check Number 11101:	0.00	6,070.00
11102	10201 031921 040221	CENTRE COUNTY UNITED WAY U WAY U WAY	03/31/2021		32.00 32.00
			Total for Check Number 11102:	0.00	64.00
11103	10231 507169 507501 507501	CLEARFIELD WHOLESALE PAPER CO WIPER DUTY TOWEL WIPER DUTY	03/31/2021		71.05 59.95 93.00
			Total for Check Number 11103:	0.00	224.00
11104	10240 73677	COLLEGIATE PRIDE INC CLOTHING ALLOWANCE HOLSINGER, VA	03/31/2021		159.63

Check No	Vendor No Invoice No	Vendor Name Description	Check Date Reference	Void Checks	Check Amount
			Total for Check Number 11104:	0.00	159.63
11105	10241 47879	COLONIAL PRESS 500 ABSENTEE REPORTS	03/31/2021		126.00
			Total for Check Number 11105:	0.00	126.00
11106	10243 10006-MAR21 10007-MAR21 20006-MAR31	COLUMBIA GAS OF PA INC GAS GAS GAS	03/31/2021		219.78 1,416.22 29.54
			Total for Check Number 11106:	0.00	1,665.54
11107	10275 9402426830 9402426832	CRAFCO INC-BIRMINGHAM ELEMENT/VALVE FILTER ELEMENT	03/31/2021		140.23 54.91
			Total for Check Number 11107:	0.00	195.14
11108	11336 49	F.O.P. LODGE #37 7 EA PA POLICEMAN'S SHORTGUIDE	03/31/2021		205.00
			Total for Check Number 11108:	0.00	205.00
11109	10374 7-313-32636	FEDERAL EXPRESS STNDRD OVRNGHT AGNIK LLC	03/31/2021		26.95
			Total for Check Number 11109:	0.00	26.95
11110	11217 031921 040221	FERGUSON TOWNSHIP POLICE ASSOC POLICE UNION DUES POLICE UNION DUES	03/31/2021		420.00 420.00
			Total for Check Number 11110:	0.00	840.00
11111	10380 012921 0228221	FERGUSON TOWNSHIP SUPERVISORS TIF TRANSFERS JAN 2021 TIF TRANSFERS FEB 2021	03/31/2021		87,560.89 57,616.26
			Total for Check Number 11111:	0.00	145,177.15
11112	11635 28946118	GREAT AMERICA FINANCIAL SERVICE COPIER LEASE 5052CI	03/31/2021		217.64
			Total for Check Number 11112:	0.00	217.64
11113	11264 PSO345040-1	GROFF TRACTOR & EQUIPMENT FILTERS	03/31/2021		225.98
			Total for Check Number 11113:	0.00	225.98
11114	10492 G400541 G400541	HIRERIGHT SOLUTIONS INC POOL: FERGUSON TWNSHP - FMCSA POOL: TOWNSHIP OF FERGUSON - NONDC	03/31/2021		250.00 250.00
			Total for Check Number 11114:	0.00	500.00
11115	11286 X204076450:01 X204076468:01 X204076523:01	HUNTER KEYSTONE PETERBILT, LP BRAKE/SHOE KIT BULK/KNOTCH WHEEL	03/31/2021		344.28 10.37 317.96

Check No	Vendor No Invoice No	Vendor Name Description	Check Date Reference	Void Checks	Check Amount
	X204076526:01	DUSTSHIELD			99.08
	X204076678:01	CREDIT			-70.00
			Total for Check Number 11115:	0.00	701.69
11116	10561 1845222	JOHN DEERE FINANCIAL AIR FILTER/FILTER ELEMENT	03/31/2021		422.58
			Total for Check Number 11116:	0.00	422.58
11117	10568 130584	K & S DISTRIBUTION 0 W 20 FULL SYN	03/31/2021		69.00
			Total for Check Number 11117:	0.00	69.00
11118	10618 9308323250	LAWSON PRODUCTS INC BOLT/LEGS	03/31/2021		91.34
			Total for Check Number 11118:	0.00	91.34
11119	10644 033121 033121 033121 033121 033121	LOWES COMPANIES INC PVC BOARDS/NYLON/HEX FOR TRAILERS SIGN BOLTS BLADES/CLAMP/20V ADAP/20V MAX 6-TO LIGHT	03/31/2021		262.05 170.89 108.92 1,472.26 13.02
			Total for Check Number 11119:	0.00	2,027.14
11120	11704 040121 040121 040121 040121	MADISON NATIONAL LIFE VOL LIFE INS STD BASIC LIFE AD&D LTD	03/31/2021		583.07 878.89 788.49 1,045.12
			Total for Check Number 11120:	0.00	3,295.57
11121	10673 24370-0 25276-0 26597-0 26797-0	MCCARTNEYS INC FOLDER/PENS SIGNATURE STAMP DAVID PRIBULKA TAPE/NOTES STAPLES	03/31/2021		70.11 26.49 103.35 3.70
			Total for Check Number 11121:	0.00	203.65
11122	11807 1489718	MODEL UNIFORMS PW UNIF	03/31/2021		109.40
			Total for Check Number 11122:	0.00	109.40
11123	11332 10848 10848 10848 10848 10848 10848 10848	NTM ENGINEERING INC PW BLDG ES-382 ES-341 ES-382 ES-1114 ES-0414 ES-1119	03/31/2021		993.00 82.75 331.00 165.50 82.75 82.75 910.25
			Total for Check Number 11123:	0.00	2,648.00
11124	11378	P & A GROUP	03/31/2021		

Check No	Vendor No Invoice No	Vendor Name Description	Check Date Reference	Void Checks	Check Amount
	F73000430774	MONTHLY ADM FEE			85.50
			Total for Check Number 11124:	0.00	85.50
11125	10830	PENN PRIME TRUST	03/31/2021		
	10811	Police Liability			2,997.54
	10811	Property Insurance			7,184.03
	10811	Public Officials			3,047.77
	10811	Crime Insurance			184.21
	10811	Vehicle Insurance			3,332.45
			Total for Check Number 11125:	0.00	16,746.00
11126	10831 10799	PENN PRIME WORKERS COMPENSATI WC	03/31/2021		23,559.00
			Total for Check Number 11126:	0.00	23,559.00
11127	11422 71921088	PRAXAIR DISTRIBUTION INC GLOVES/WELD	03/31/2021		24.29
			Total for Check Number 11127:	0.00	24.29
11128	10916 8686	R C BOWMAN INC TRIAxLE LOAD SCREENED TOPSOIL/DELI	03/31/2021		566.25
			Total for Check Number 11128:	0.00	566.25
11129	10927 2900	REDLINE SPEED SHINE FLEET MEMBERSHIP	03/31/2021		280.33
			Total for Check Number 11129:	0.00	280.33
11130	10957 1936	ROY BROOKS WELDING INC 2PCS 6"CHANNEL CUT TO SIZE	03/31/2021		124.00
			Total for Check Number 11130:	0.00	124.00
11131	10977 S6067379.001 S6067379.002	SCHAEDLER YESCO DISTRIBUTION LAMP FROSTED GLASS LAMP FROSTED GLASS	03/31/2021		100.48 12.06
			Total for Check Number 11131:	0.00	112.54
11132	11017 1433509	SOSMETAL PRODUCTS INC HITCH COTTER/HOOK/MARKER/CLEVIS/M	03/31/2021		448.90
			Total for Check Number 11132:	0.00	448.90
11133	11045 10166558 10166630 10166679	STEPHENSON EQUIPMENT INC FILTER FILTER GAUGE FILTER	03/31/2021		98.79 47.30 72.45
			Total for Check Number 11133:	0.00	218.54
11134	11136 6181108 6181131	U S MUNICIPAL SUPPLY INC BOLT SIGNS	03/31/2021		60.00 1,407.40
			Total for Check Number 11134:	0.00	1,467.40
11135	11137	ULINE	03/31/2021		

Check No	Vendor No Invoice No	Vendor Name Description	Check Date Reference	Void Checks	Check Amount
	131381989	NEW GARBAGE CANS			323.23
			Total for Check Number 11135:	0.00	323.23
11136	11173 WS02367	WALKER & WALKER EQUIPMENT II I FIX EXHAUST VALVE	03/31/2021 VOID		396.53
			Total for Check Number 11136:	396.53	0.00
11137	11668 011921	CRAIG M. WALTERS, LCSW EOB	03/31/2021		20.00
			Total for Check Number 11137:	0.00	20.00
11138	11192	WEST PENN POWER	03/31/2021		
	0873-MAR21	WHITEHALL RD/W COLLEGE	01.433.036		40.14
	1054-MAR21	W COLLEGE AVE	01.433.036		49.26
	1966-MAR21	225 SCIENCE PARK RD	01.433.036		30.44
	2449-MAR21	WESTERLY PKWY BLUE CR	01.433.036		33.36
	2510-MAR21	W CHERRY LN MARTIN ST	01.433.036		37.94
	2691-MAR21	SCIENCE PARK ROAD	01.433.036		31.22
	2711-MAR21	SCIENCE PARK ROAD	01.433.036		43.37
	3377-MAR21	BRISTOL AVE	01.433.036		35.07
	5290-MAR21	1901 CIRCLEVILLE ROAD	01.433.036		31.05
	5727-MAR21	OFFICE COMPLEX	01.409.036		1,287.78
	5843-MAR21	1301 W COLLEGE AVE	01.433.036		36.11
	6113-MAR21	GARAGE/MAINT BLDG	01.409.036		431.92
	6150-MAR21	OLD GATESBURG ROAD	01.433.036		68.81
	6438-MAR21	1209 N ATHERTON ST	01.433.036		24.65
	6651-MAR21	BIKE TUNNEL	01.433.036		99.69
	6725-MAR21	BLDG #3	01.409.036		437.47
	6735-MAR21	N HILLS DR	01.433.036		26.49
	7595-MAR21	1282 N ATHERTON ST	01.433.036		35.63
	7920-MAR21	N ATHERTON ST	01.433.036		20.72
	8100-MAR21	2100 W COLLEGE AVE	01.433.036		43.27
	8136-MAR21	BLUE COURSE DR & HAVENSHIRE DR	01.433.036		34.19
	9110-MAR21	W COLLEGE AVE	01.433.036		31.35
	9608-MAR21	3147 RESEARCH DRIVE	01.409.036		1,558.38
	9975-MAR21	AARON DR MARTIN ST	01.433.036		33.41
			Total for Check Number 11138:	0.00	4,501.72
11139	11199 1109388-01	WILLIAMS BROTHERS HEX/FLAT WASHER	03/31/2021		80.00
			Total for Check Number 11139:	0.00	80.00
11140	10771 2115713	WITMER PUBLIC SAFETY GROUP INC PISTOL TACO MOLLE HOLDS ONE PISTOL	03/31/2021		91.00
			Total for Check Number 11140:	0.00	91.00
11141	11262 9415	X-PERT COMMUNICATIONS FOUND ADA MOTOR IS NOT FUNCTIONIN	03/31/2021		75.00
			Total for Check Number 11141:	0.00	75.00
2017096	11892 E3X52101-04	JACOBS ENGINEERING GROUP INC TRAFFIC SIGNAL SYSTEM CONSULTING S	03/14/2021		2,423.84
			Total for Check Number 2017096:	0.00	2,423.84

Check No	Vendor No Invoice No	Vendor Name Description	Check Date Reference	Void Checks	Check Amount
2017097	11914 3	NATIONAL WATER MAIN CLEANING C CIPP LINING	03/14/2021		53,200.76
Total for Check Number 2017097:				0.00	53,200.76
20200915	11895 022221	THE CINCINNATI INSURANCE COMPA TUDEK PARK	03/11/2021		6,974.00
Total for Check Number 20200915:				0.00	6,974.00
20200916	11192 6563-MAR21	WEST PENN POWER 425 PARK CREST LANE	03/31/2021 93.454.249		95.91
Total for Check Number 20200916:				0.00	95.91
Report Total (145 checks):				51,444.51	1,060,840.61





# *MONTHLY TREASURERS REPORT*

**FEBRUARY 2021**

## CASH BALANCES BY FUND - FEBRUARY 28, 2021

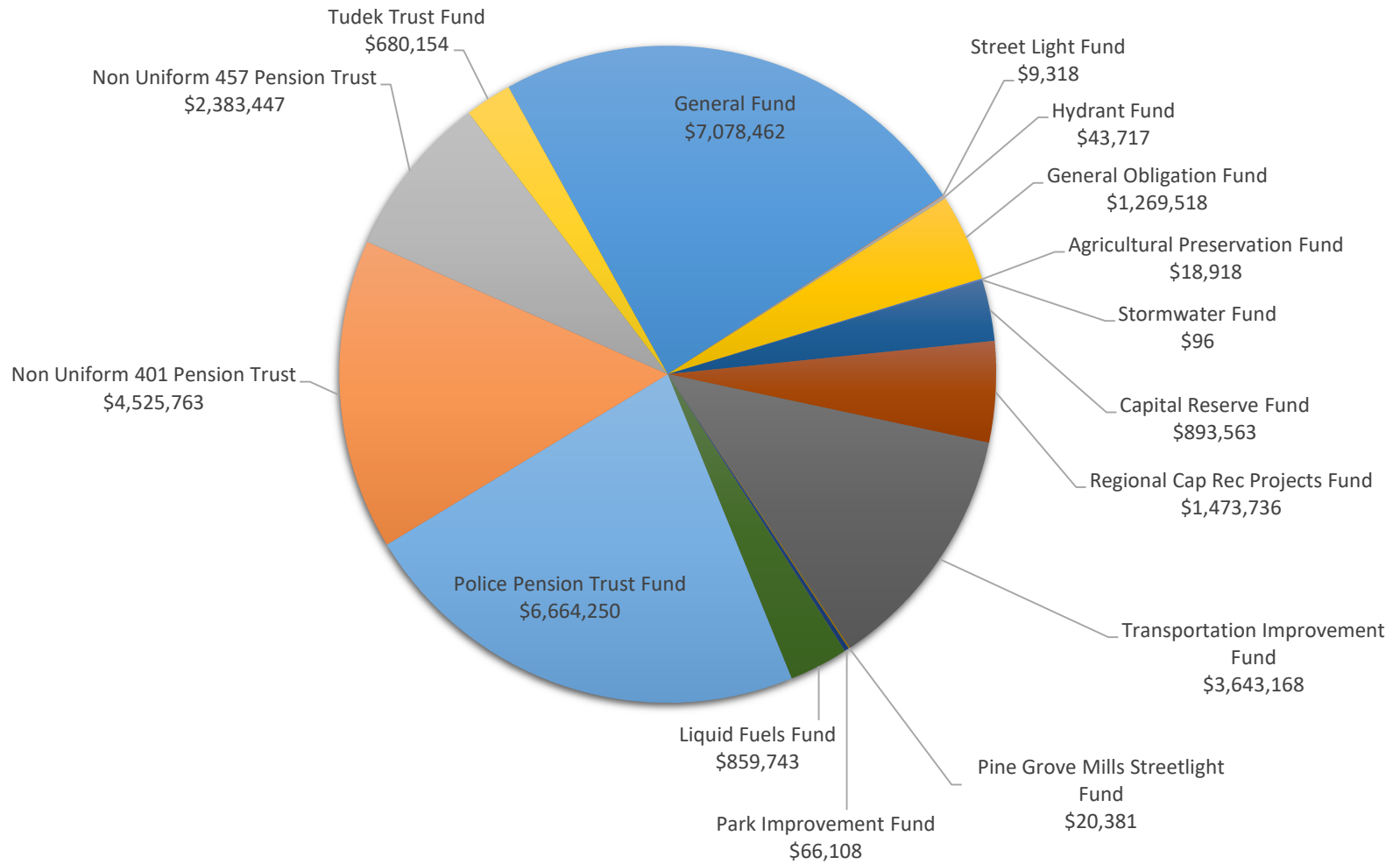

# Ferguson Township Treasurer's Report

February 28, 2021

## Statement of Cash Balances

### General Fund

**Checking**

Jersey Shore State Bank Operating Checking (3245)	3,014,362.08
Jersey Shore State Bank Investment Checking (5531)	2,318,590.16
JSSB Flex Plan Checking (8757)	18,339.30
Ameriserv Money Market 2602	262,992.15
Ameriserv CD (0210) (matures 12/3/21)(1/3 of total)	268,156.08
PLGIT General Fund Class (3017)	393,115.41
PLGIT General Fund Prime (3017)	802,906.44

**TOTAL GENERAL FUND**

**7,078,461.62**

### Other Funds

**Fund 02 Street Lights**

JSSB Checking (4836)	9,317.54
----------------------	----------

**Fund 03 Fire Hydrant**

JSSB Checking (4844)	43,717.17
----------------------	-----------

**Fund 16 General Obligation**

JSSB Checking (4852)	341,379.04
JSSB 2019 Bond Checking	928,138.71

**Fund 19 Agricultural Preservation**

JSSB Checking (4879)	18,918.45
----------------------	-----------

**Fund 20 Stormwater Fund**

JSSB Checking (1711)	95.80
----------------------	-------

**Fund 30 Capital Reserve**

Paypal Account	29,889.08
JSSB Checking (Employee Wellness Sinking Fund)(4909)	15,573.23
JSSB Capital Reserve Checking (3555)	(13,380.39)
JSSB Checking (PW Equipment Sinking Fund)(4895)	578,129.30
JSSB Checking (Bldg Equipment Sinking Fund)(4887)	283,351.64

**Fund 31 Regional Capital Recreation Projects**

JSSB Checking (3547)	942,587.77
Ameriserv Money Market 2818	262,992.15
Ameriserv CD (0210) (matures 12/3/21)(1/3 of total)	268,156.08

**Fund 32 Transportation Improvement**

JSSB Checking (3539)	1,789,482.50
PLGIT Checking (Class & Plus)(3261)	315,504.45
PLGIT Checking (Prime)(3261)	1,007,033.02
Ameriserv Money Market 2693	262,992.15
Ameriserv CD (0210) (matures 12/3/21)(1/3 of total)	268,156.08

**Fund 33 Pine Grove Mills Street Lights**

JSSB Checking (4917)	20,380.93
----------------------	-----------

**Fund 34 Park Improvement**

# Ferguson Township Treasurer's Report

February 28, 2021

## Statement of Cash Balances

JSSB Checking (4925)	66,108.10
<b><u>Fund 35 Liquid Fuels</u></b>	
JSSB Checking (4933)	140,602.07
PLGIT Checking (Class) (3020)	317,645.88
PLGIT Checking (Prime) (3020)	401,495.54
<b><u>Fund 93 Tudek Memorial Trust</u></b>	
JSSB Checking (4976)	8,905.57
FNB Investments (@market)	164,624.49
Centre Foundation Investments	506,623.57
<b>TOTAL OTHER FUNDS</b>	<b>8,978,419.92</b>
<b>TOTAL NON PENSION FUNDS</b>	<b>16,056,881.54</b>
<b>Employer Pension Trust Funds</b>	
<b><u>Fund 60 Police Pension Trust</u></b>	
JSSB Checking (4941)	17,815.40
PNC Enterprise Checking (9642)	52,440.47
PNC Investments (@market)(includes accrued interest)	6,593,993.70
<b><u>Fund 65 Non Uniformed 401a Pension Trust</u></b>	
JSSB Checking (4968)	62.80
ICMA-RHS (801695) Employee Retirement Health Savings Trust (@ market)	100,742.09
ICMA-401 (108860) Employer Pension Investment Trust (@ market)	4,424,957.69
<b>TOTAL PENSION TRUST FUNDS</b>	<b>11,190,012.15</b>
<b>GRAND TOTAL</b>	<b>27,246,893.69</b>
<b>Employee Pension Trust Funds</b>	
<b><u>Fund 66 Non Uniformed 457 Pension Trust</u></b>	
ICMA-457 (300747) Employee Pension Investment Trust (@ market)	2,336,646.85
ICMA-ROTH IRA (706007) Employee Pension Investment Trust (@ market)	46,800.32
	<b>2,383,447.17</b>

# Bank Reconciliation

## Uncleared Checks by Fund

User: eendresen  
Printed: 04/28/2021 - 12:52PM  
Checks Before: 02/28/2021



Fund/Check No.	Check Date	Clear Date	System	Vendor/Employee No.	Vendor/Employee Name	Amount
01	GENERAL FUND					
0	02/15/2021	Uncleared	AP	10870	PNC INSTITUTIONAL INVESTMENTS	3,546.37
0	02/15/2021	Uncleared	AP	11216	VANTAGEPOINT TRANSFER AGENTS 401	8,519.43
0	02/15/2021	Uncleared	AP	11218	VANTAGEPOINT TRANSFER AGENTS 457	7,680.54
0	02/15/2021	Uncleared	AP	11381	VANTAGEPOINT TRANSFER AGENTS-706007 ROTH	233.09
0	02/26/2021	Uncleared	AP	10870	PNC INSTITUTIONAL INVESTMENTS	3,546.37
0	02/26/2021	Uncleared	AP	11216	VANTAGEPOINT TRANSFER AGENTS 401	8,675.50
0	02/26/2021	Uncleared	AP	11218	VANTAGEPOINT TRANSFER AGENTS 457	6,744.42
0	02/26/2021	Uncleared	AP	11381	VANTAGEPOINT TRANSFER AGENTS-706007 ROTH	233.09
9001	08/22/2019	Uncleared	AP	10263	CORMANS MAIL SERVICE	2,873.11
9183	10/15/2019	Uncleared	AP	11593	HOME DEPOT CREDIT SERVICES	288.05
9272	11/15/2019	Uncleared	AP	10035	ALS TECHNOLOGIES INC	1,145.00
9297	11/15/2019	Uncleared	AP	11253	INFRADAPT LLC	3,221.44
9340	11/29/2019	Uncleared	AP	11855	ANDERSON INDUSTRIAL MACHINERY	769.80
9437	12/31/2019	Uncleared	AP	10035	ALS TECHNOLOGIES INC	1,145.00
9562	01/20/2020	Uncleared	AP	11173	WALKER & WALKER EQUIPMENT II LLC	43.19
9725	02/28/2020	Uncleared	AP	11248	CENTRO PRINT SOLUTIONS	100.17
9806	03/15/2020	Uncleared	AP	11797	LANDPRO EQUIPMENT LLC	759.15
9874	03/31/2020	Uncleared	AP	11877	RUSSIAN CHURCH OF CHRIST	78.11
9937	04/30/2020	Uncleared	AP	11219	COMMONWEALTH OF PENNSYLVANIA	50.00
10091	05/31/2020	Uncleared	AP	11490	RECONYX, INC	970.51
10331	08/14/2020	Uncleared	AP	10244	COMCAST	1,050.00
10444	09/15/2020	Uncleared	AP	10208	CENTRE REGION COUNCIL OF GOVERNMENTS	22.50
10471	09/15/2020	Uncleared	AP	10813	PARK TRAVIS	16.10
10602	10/15/2020	Uncleared	AP	10893	PRINT O STAT INC	1,849.00
10736	11/30/2020	Uncleared	AP	11918	HOOVER DEREK J.	121.42
10774	12/15/2020	Uncleared	AP	10346	ECOLAWN	90.00
10842	12/31/2020	Uncleared	AP	10435	GFOA PA	75.00
10865	12/31/2020	Uncleared	AP	10881	PORT MATILDA FIRE COMPANY	3,500.00
10908	01/15/2021	Uncleared	AP	10846	PENNSYLVANIA MUNICIPAL LEAGUE	2,264.32
10915	01/30/2021	Uncleared	AP	11239	ASAP HYDRAULICS STATE COLLEGE, INC	42.99

Fund/Check No.	Check Date	Clear Date	System	Vendor/Employee No.	Vendor/Employee Name	Amount
10920	01/30/2021	Uncleared	AP	11930	BUDS ELECTRIC	437.01
10938	01/30/2021	Uncleared	AP	10346	ECOLAWN	135.00
10946	01/30/2021	Uncleared	AP	11791	JOHNSON CONTROLS INC	4,600.00
10974	01/30/2021	Uncleared	AP	10493	THE HITE COMPANY	75.84
10977	01/30/2021	Uncleared	AP	11150	VALLEY FAB & EQUIPMENT INC	346.20
10994	02/15/2021	Uncleared	AP	10201	CENTRE COUNTY UNITED WAY	32.00
10995	02/15/2021	Uncleared	AP	10203	CENTRE DAILY TIMES	1,186.55
10996	02/15/2021	Uncleared	AP	10206	CENTRE LIFELINK EMS	661.25
10997	02/15/2021	Uncleared	AP	11248	CENTRO PRINT SOLUTIONS	65.88
11001	02/15/2021	Uncleared	AP	10247	COMMONWEALTH OF PA	35.00
11002	02/15/2021	Uncleared	AP	10346	ECOLAWN	90.00
11004	02/15/2021	Uncleared	AP	10396	FISHER AUTO PARTS	775.30
11005	02/15/2021	Uncleared	AP	11445	GIANT FOOD STORES LLC	35.00
11008	02/15/2021	Uncleared	AP	10568	K & S DISTRIBUTION	10,273.40
11009	02/15/2021	Uncleared	AP	10618	LAWSON PRODUCTS INC	218.65
11010	02/15/2021	Uncleared	AP	10762	MARCO	488.60
11013	02/15/2021	Uncleared	AP	10673	MCCARTNEYS INC	86.16
11014	02/15/2021	Uncleared	AP	11812	MEDEXPRESS	78.00
11017	02/15/2021	Uncleared	AP	10773	OLD DOMINION BRUSH COMPANY INC.	393.61
11018	02/15/2021	Uncleared	AP	10784	PA CHAPTER OF APA - CENTRAL SECTION	112.00
11020	02/15/2021	Uncleared	AP	11422	PRAXAIR DISTRIBUTION INC	109.79
11021	02/15/2021	Uncleared	AP	10927	REDLINE SPEED SHINE	560.66
11022	02/15/2021	Uncleared	AP	10932	RESERVE ACCOUNT	3,000.00
11026	02/15/2021	Uncleared	AP	11029	STAHL SHEAFFER ENGINEERING LLC	24,405.22
11028	02/15/2021	Uncleared	AP	11887	STUCK ENTERPRISE CO	15,577.91
11030	02/15/2021	Uncleared	AP	11113	TRACTOR SUPPLY CREDIT PLAN	611.99
11031	02/15/2021	Uncleared	AP	11152	VALLEY TRUCK & TRAILER SALES & SERVICE INC	314.64
11032	02/15/2021	Uncleared	AP	11159	VERIZON WIRELESS	302.57
11034	02/15/2021	Uncleared	AP	11192	WEST PENN POWER	955.52
20200902	02/26/2021	Uncleared	AP	10016	AFLAC	118.17
20200904	02/26/2021	Uncleared	AP	11239	ASAP HYDRAULICS STATE COLLEGE, INC	198.58
20200905	02/26/2021	Uncleared	AP	11649	BABST CALLAND CLEMENTS AND ZOMNIR P.C.	945.00
20200906	02/26/2021	Uncleared	AP	11910	BARTON ASSOCIATES	700.00
20200907	02/26/2021	Uncleared	AP	10120	BORING COURT REPORTING	150.00
20200908	02/26/2021	Uncleared	AP	10122	BOROUGH OF STATE COLLEGE	65.09
20200909	02/26/2021	Uncleared	AP	10124	BOTTI D O KASANDRA	250.00
20200910	02/26/2021	Uncleared	AP	10148	CALIBRE PRESS	1,656.00
20200911	02/26/2021	Uncleared	AP	10176	CENTRAL PA CHIEFS OF POLICE	50.00
20200912	02/26/2021	Uncleared	AP	10184	CENTRE COMMUNICATIONS INC	170.00
20200913	02/26/2021	Uncleared	AP	10201	CENTRE COUNTY UNITED WAY	32.00
20200915	02/26/2021	Uncleared	AP	10231	CLEARFIELD WHOLESALE PAPER COMPANY INC	375.22

Fund/Check No.	Check Date	Clear Date	System	Vendor/Employee No.	Vendor/Employee Name	Amount
20200916	02/26/2021	Uncleared	AP	10234	CLEVELAND BROTHERS EQUIP CO INC	106.28
20200917	02/26/2021	Uncleared	AP	10142	CNET	2,215.54
20200918	02/26/2021	Uncleared	AP	10241	COLONIAL PRESS	1,062.00
20200919	02/26/2021	Uncleared	AP	10243	COLUMBIA GAS OF PA INC	4,527.36
20200920	02/26/2021	Uncleared	AP	10284	CUSTOM ALTERATIONS	11.00
20200921	02/26/2021	Uncleared	AP	10297	DAVIDHEISERS INC	1,266.00
20200922	02/26/2021	Uncleared	AP	11737	ECO-MAXX	201.50
20200924	02/26/2021	Uncleared	AP	11217	FERGUSON TOWNSHIP POLICE ASSOCIATION	420.00
20200925	02/26/2021	Uncleared	AP	10383	FERGUSON TWP AREA SENIOR CITIZENS GROUP	500.00
20200926	02/26/2021	Uncleared	AP	11483	FORCE AMERICA DISTRIBUTING LLC	393.61
20200927	02/26/2021	Uncleared	AP	10409	FRED CARSON DISPOSAL INC.	11.00
20200929	02/26/2021	Uncleared	AP	11727	HUNTER TRUCK SALES	575.75
20200930	02/26/2021	Uncleared	AP	10515	HYDRAULIC SOLUTIONS INC	654.00
20200931	02/26/2021	Uncleared	AP	11253	INFRADAPT LLC	655.80
20200932	02/26/2021	Uncleared	AP	10554	JARU ASSOCIATES INC	70.00
20200933	02/26/2021	Uncleared	AP	10506	KEYSTONE CONSTRUCTION AND EARTHWORK LLC	13,680.00
20200934	02/26/2021	Uncleared	AP	10618	LAWSON PRODUCTS INC	177.97
20200935	02/26/2021	Uncleared	AP	11704	MADISON NATIONAL LIFE	2,291.29
20200936	02/26/2021	Uncleared	AP	10762	MARCO	473.03
20200937	02/26/2021	Uncleared	AP	11839	MARCO TECHNOLOGIES LLC	293.50
20200938	02/26/2021	Uncleared	AP	10667	MATHESON TRI GAS INC DBA	158.87
20200939	02/26/2021	Uncleared	AP	10669	MAXWELL TRUCK & EQUIPMENT LLC	1,502.37
20200940	02/26/2021	Uncleared	AP	10673	MCCARTNEYS INC	36.57
20200941	02/26/2021	Uncleared	AP	10679	MCMONAGLE DAVID	100.00
20200942	02/26/2021	Uncleared	AP	10701	MILLER WELDING SERVICE	490.00
20200943	02/26/2021	Uncleared	AP	11807	MODEL UNIFORMS	328.20
20200944	02/26/2021	Uncleared	AP	10712	MONARCH CLEANERS	189.65
20200945	02/26/2021	Uncleared	AP	10760	NOERR'S INTERNATIONAL - LEWISTOWN	261.76
20200946	02/26/2021	Uncleared	AP	11332	NTM ENGINEERING INC	6,233.75
20200947	02/26/2021	Uncleared	AP	11378	P & A GROUP	85.50
20200948	02/26/2021	Uncleared	AP	10785	PA CHIEFS OF POLICE ASSOCIATION	1,150.00
20200949	02/26/2021	Uncleared	AP	10830	PENN PRIME TRUST	40,309.00
20200950	02/26/2021	Uncleared	AP	10831	PENN PRIME WORKERS COMPENSATION TRUST	36,195.00
20200951	02/26/2021	Uncleared	AP	10846	PENNSYLVANIA MUNICIPAL LEAGUE	65.00
20200952	02/26/2021	Uncleared	AP	11422	PRAXAIR DISTRIBUTION INC	24.29
20200953	02/26/2021	Uncleared	AP	11902	PRECISE TRIAL, LLC	1,213.24
20200954	02/26/2021	Uncleared	AP	10955	ROTHROCKS LOCKSMITH	260.00
20200955	02/26/2021	Uncleared	AP	10973	SAMS CLUB / SYNCHRONY BANK	100.00
20200956	02/26/2021	Uncleared	AP	11614	SNAP ON INDUSTRIAL	328.76
20200957	02/26/2021	Uncleared	AP	11017	SOSMETAL PRODUCTS INC	266.25
20200958	02/26/2021	Uncleared	AP	11012	SPRINGBROOK NATIONAL USER GROUP	100.00

Fund/Check No.	Check Date	Clear Date	System	Vendor/Employee No.	Vendor/Employee Name	Amount
20200959	02/26/2021	Uncleared	AP	11794	SPRINGBROOK HOLDING COMPANY, LLC	18,372.90
20200960	02/26/2021	Uncleared	AP	11887	STUCK ENTERPRISE CO	3,707.00
20200961	02/26/2021	Uncleared	AP	11665	TERMINAL SUPPLY COMPANY	139.31
20200962	02/26/2021	Uncleared	AP	10493	THE HITE COMPANY	116.91
20200963	02/26/2021	Uncleared	AP	11137	ULINE	123.05
20200964	02/26/2021	Uncleared	AP	11192	WEST PENN POWER	2,755.90
20200965	02/26/2021	Uncleared	AP	11199	WILLIAMS BROTHERS	243.27
20200966	02/26/2021	Uncleared	AP	10771	WITMER PUBLIC SAFETY GROUP INC	276.00
Fund 01Total:						275,045.66
02	STREET LIGHT FUND					
143	02/15/2021	Uncleared	AP	11192	WEST PENN POWER	21.71
Fund 02Total:						21.71
30	CAPITAL RESERVE FUND					
806	12/15/2020	Uncleared	AP	10755	THE HON COMPANY	18,730.00
829	02/15/2021	Uncleared	AP	10236	CMT LABORATORIES	70.00
830	02/15/2021	Uncleared	AP	11675	GREENFIELD ARCHITECTS LTD	20,422.91
831	02/15/2021	Uncleared	AP	11881	LEONARD S. FIORE INC	301,809.26
832	02/15/2021	Uncleared	AP	11881	LEONARD S. FIORE INC	439,553.60
834	02/15/2021	Uncleared	AP	11888	WESTMORELAND ELECTRIC SERVICES LLC	60,297.66
835	02/26/2021	Uncleared	AP	10236	CMT LABORATORIES	67.50
836	02/26/2021	Uncleared	AP	11264	GROFF TRACTOR & EQUIPMENT	7,601.00
837	02/26/2021	Uncleared	AP	11165	VIGILANT SECURITY	656.74
838	02/26/2021	Uncleared	AP	11888	WESTMORELAND ELECTRIC SERVICES LLC	122,394.02
Fund 30Total:						971,602.69
34	PARK IMPROVEMENT FUND					
57	02/26/2021	Uncleared	AP	11332	NTM ENGINEERING INC	8,471.58
Fund 34Total:						8,471.58
35	LIQUID FUELS FUND					
392	02/15/2021	Uncleared	AP	11228	AMERICAN ROCK SALT COMPANY LLC	14,650.45
393	02/15/2021	Uncleared	AP	10231	CLEARFIELD WHOLESALE PAPER COMPANY INC	1,094.88
394	02/26/2021	Uncleared	AP	11228	AMERICAN ROCK SALT COMPANY LLC	39,461.97
Fund 35Total:						55,207.30
93	TUDEK PARK TRUST FUND					
210	02/09/2021	Uncleared	AP	11035	STATE COLLEGE BOROUGH WATER AUTHORITY	20.80



<b>Fund/Check No.</b>	<b>Check Date</b>	<b>Clear Date</b>	<b>System</b>	<b>Vendor/Employee No.</b>	<b>Vendor/Employee Name</b>	<b>Amount</b>
20200913	02/01/2021	Uncleared	AP	10844	PENNSYLVANIA EQUINE COUNCIL	76.64
20200914	02/15/2021	Uncleared	AP	11192	WEST PENN POWER	81.75
Fund 93Total:						179.19
Grand Total:						1,310,528.13

RESOLUTION NO. \_\_\_\_\_

**A RESOLUTION OF THE TOWNSHIP OF FERGUSON, CENTRE COUNTY, PENNSYLVANIA, AUTHORIZING THE DISPOSITION OF SPECIFIC PUBLIC RECORDS IN ACCORDANCE WITH THE PROCEDURES SET FORTH IN THE RETENTION AND DISPOSITION SCHEDULE FOR RECORDS OF PENNSYLVANIA MUNICIPALITIES ISSUED JULY 16, 1993 AND AS AMENDED DECEMBER 16, 2008.**

**WHEREAS**, by virtue of Resolution 86-11, adopted on September 23, 1986, the Township of Ferguson declared its intent to follow the schedules and procedures for the disposition of records as set forth in the Municipal Records Manual as amended; and

**WHEREAS**, in accordance with Act 428 of 1968, each individual act of disposition shall be approved by resolution of the governing body of the municipality.

**NOW, THEREFORE, BE IT RESOLVED**, that the Board of Supervisors of the Township of Ferguson, Centre County, Pennsylvania, in accordance with the above-cited Municipal Records Manual, hereby authorizes the disposition and destruction of the public records as listed in Exhibit "A", attached hereto.

**ADOPTED**, this 3<sup>rd</sup> day of May, 2021.

**TOWNSHIP OF FERGUSON  
BOARD OF SUPERVISORS**

By: \_\_\_\_\_  
Laura Dininni, Chair

[ S E A L ]

**ATTEST:**

By: \_\_\_\_\_  
David G. Pribulka, Secretary

## EXHIBIT "A"

The following records have been marked for destruction in accordance with the Disposition Schedule for Records of Pennsylvania Municipalities issued July 16, 1993;

### **Administration & Finance**

Storage Box No.	Description of Contents
F232	2012 Vendors A-F
F233	2012 Vendors G-M
F234	2012 Vendors N-S
F235	2012 Vendors T-Z
F236	2012 Time Sheets
F237	2012 General Fund Deposits January - July
F238	2012 General Fund Deposits August - December
F239	2012 PLGIT Statements; Curbs; Escrow; Accruals; 2012 Payroll Transmittal Sheets
F240	2012 BMO Credit Card; Correspondence 2012
F241	2013 Vendors A-F
F242	2013 Vendors G-O
F243	2013 Vendors P-U
F244	2013 Vendors V-Z
F245	2013 Correspondence
F246	2013 PLGIT Statements
F247	2013 Timesheets
F248	2013 Jan. – May General Fund Deposits
F249	2013 June – Dec. General Fund Deposits
F250	2012 W-9 Info; 2013 Escrows; Curbs
F251	2009 Audit; 2009-2013 CIP; 2010 Budget

### **Tax Office**

Storage Box No.	Description of Contents
TR302	2009 Duplicate/Supplement/Reports/Bills
TR303	2010 Duplicate/Supplement/Reports/Bills
TE/100-12	Bank Statements Earned Income & General
TE178	2009 EIT Withholding Quarterly & Final Returns
TE179	2010 EIT Withholding Quarterly & Final Returns

### **Police Department**

Storage Box No.	Description of Contents
P252	1999 Police Case Reports (0001-0999)
P253	1999 Police Case Reports (1000-2399)
P254	1999 Police Case Reports (2400-3299)
P255	1999 Police Case Reports (3300–3698)
P256	2014 Alarm letters, Disseminations, Back Ground Checks, Non Reportable Crashes, Traffic & Non-Traffic Citations and Warning Cards, NCIC,
P257	2015 Officer Daily Reports
P258	2000 Police Case Reports (0013-1188)
P259	2000 Police Case Reports (1242-2190)
P260	2000 Police Case Reports (2191-3502)
P261	2000 Police Case Reports (3503–4300)
P262	2015 Alarm letters, Disseminations, Back Ground Checks, Non Reportable Crashes, Traffic & Non-Traffic Citations and Warning Cards, NCIC,

**RESOLUTION NO. \_\_\_\_\_**

**A RESOLUTION OF THE TOWNSHIP OF FERGUSON, CENTRE COUNTY PENNSYLVANIA, AMENDING RESOLUTION 2020-41, THE OFFICIAL TOWNSHIP PLANT LIST.**

**Section 1.** The Board of Supervisors of the Township of Ferguson established by Resolution 1999-36 and amended by Resolutions 2000-22 and 2020-41, an Official Township Plant List to be used as a guide for the selection of appropriate trees and landscape planting materials. Said Official Township Plant List is required to be used for land development and subdivision plans where a landscaping plan, tree preservation plan, or street trees are required.

**Section 2.** The Official Township Plant List is hereby amended by adding Salix discolor – Pussy willow to the list, attached hereto as Exhibit "A".

**Section 3.** Now, therefore, the Board of Supervisors of the Township of Ferguson resolves to amend the Official Township Plan List for the Township of Ferguson, attached hereto.

**RESOLVED**, this 3<sup>rd</sup> day of May, 2021

**TOWNSHIP OF FERGUSON**

By \_\_\_\_\_  
Laura Dininni, Chair  
Board of Supervisors

[SEAL]

ATTEST:

By \_\_\_\_\_  
David G. Pribulka, Secretary

## Exhibit "A"

### Canopy Trees

- *Acer xfreemanii* - Freeman maple (intentional cross between *A. rubrum* and *A. saccharinum*, becoming widely available in nursery trade.)
- *Acer rubrum*-Red Maple
- *Acer saccharinum*-Silver Maple
- *Acer saccharum*-Sugar Maple
- *Acer truncatum* X *A. Platanoides*-Pacific Sunset Maple
- *Aesculus c. carnea*- red horsechestnut
- *Aesculus glabra*-Ohio Buckeye
- *Betula alleghaniensis* -Yellow birch
- *Betula lenta*-Sweet Birch
- *Betula nigra*-River Birch
- *Betula populifolia* - Gray birch
- *Betula papyrifera*-Paper Birch
- *Carya glabra*-Pignut Hickory
- *Carya laciniosa*-Shellbark Hickory
- *Carya ovata*-Shagbark Hickory
- *Carya tomentosa*-Mockernut Hickory
- *Catalpa speciosa*-Catalpa
- *Celtis occidentalis*-Northern Hackberry
- *Cladrastis kentukea*-American Yellowwood
- *Diospyros virginiana*- American persimmon
- *Eucommia ulmoides*-Hardy Rubber Tree
- *Fagus grandifolia*-American Beech
- *Ginkgo biloba*-Ginkgo
- *Gleditsia triacanthos*-Thornless Common Honeylocust
- *Gymnocladus dioica*-Kentucky Coffee Tree
- *Halesia carolina*-Carolina Silverbell
- *Liquidambar styraciflua*-Sweetgum
- *Liriodendron tulipifera*-Tulip Tree
- *Magnolia acuminata*-Cucumber Tree
- *Morus rubra* - Red mulberry
- *Nyssa sylvatica*-Blackgum
- *Ostrya virginiana*-American Hophornbeam
- *Oxydendrum arboreum*-Sourwood
- *Platanus X acerifolia*-London Plane Tree
- *Platanus occidentalis*-Sycamore
- *Populus grandidentata*-Bigtooth Aspen
- *Populus tremuloides*- Quaking aspen
- *Prunus sargentii*-Sargent Cherry
- *Prunus serotina*-Black Cherry
- *Prunus serrulata*-Kwanzan Cherry

- Quercus acutissima-Sawtooth Oak
- Quercus alba-White Oak
- Quercus bicolor-Swamp White Oak
- Quercus coccinea-Scarlet Oak
- Quercus imbricaria-Shingle Oak
- Quercus macrocarpa-Bur Oak
- Quercus muehlenbergi-Chinkapin Oak
- Quercus palustris-Pin Oak
- Quercus phellos-Willow Oak
- Quercus montana-Chestnut Oak
- Quercus rubra-Northern Red Oak
- Quercus shumardii-Shumard Oak
- Quercus velutina -Black oak
- Robinia pseudoacacia- Black Locust
- Sassafras albidum-Common Sassafras
- Tilia americana-American Linden
- Tilia cordata-Littleleaf Linden
- Tilia tomentosa-Sterling Silver Linden
- Zel.kova serrata-Japanese Zelkova

### **Understory Trees**

- Alnus serrulate –Smooth Alder
- Acer pensylvanicum – Striped maple
- Amelanchier sp.-Serviceberry
- Carpinus caroliniana-American Hornbeam
- Cercis canadensis-Eastern Redbud
- Cornus alternifolia-Pagoda Dogwood
- Cornus amomum-Silky Dogwood
- Cornus florida-Flowering Dogwood
- Cornus kousa-Kousa Dogwood
- Cornus mas-Carnelian Cherry Dogwood
- Crataegus phaenopyrum-Washington Hawthorn
- Crataegus punctata-Pioneer Hawthorn
- Crataegus viridis-Winter Green Hawthorn
- Hamamelis virginiana -Witch-hazel
- Hamamelis x (various hybrids) –Witch-hazel
- Ilex opaca – American Holly
- Magnolia-Galaxy Magnolia
- Magnolia stellate-Star Magnolia
- Magnolia virginiana-Sweetbay Magnolia
- Malus sp.-Crabapple

- *Prunus americana*-Wild Plum
- *Prunus okame*-Okame Cherry
- *Prunus virginiana*-Choke Cherry
- *Rhus glabra*- Smooth sumac
- *Rhus typhina* –Staghorn sumac
- *Salix nigra*-Black Willow
- *Salix sericea*-Silky Willow
- *Sorbus americana* -American mountain-ash
- *Syringa reticulata* -Japanese Tree Lilac

#### Evergreen trees

- *Abies concolor* –Concolor fir
- *Abies fraseri*-Fraser Fir
- *Juniperus virginiana* – Eastern redcedar
- *Larix laricina*-American Larch (deciduous)
- *Metasequoia glyptostroboides*-Dawn Redwood
- *Picea abies*-Norway Spruce
- *Pinus banksiana* –Jack Pine
- *Pinus bungeana*-Lacebark Pine
- *Pinus nigra*-Austrian Pine
- *Pinus resinosa*-Red Pine
- *Pinus rigida*-Pitch Pine
- *Pinus strobus*-Eastern White Pine
- *Pinus sylvestris*-Scotch Pine
- *Pinus taeda*-Loblolly Pine
- *Pinus virginiana*-Virginia Pine
- *Taxodium distichum*-Baldcypress
- *Thuja occidentalis* – Northern white cedar

#### Shrubs

- *Aesculus parviflora*-Bottlebrush Buckeye
- *Alnus serrulata*-Smooth Alder
- *Aronia arbutifolia*-Red Chokeberry
- *Aronia melanocarpa*-Black Chokeberry
- *Azalea* species-Azalea
- *Buxus sempervirens*-English Boxwood
- *Calycanthus floridus*-Sweetshrub
- *Ceanothus americanus*-New Jersey Tea
- *Cephalanthus occidentalis*-Buttonbush
- *Chaenomeles speciose*-Flowering Quince

- *Clethra alnifolia*-Summersweet
- *Corylus americana*-American Hazelnut
- *Cornus amomum*-Silky Dogwood
- *Cornus sericea*-Red-osier Dogwood
- *Cornus stolonifera*-Red Twig Dogwood
- *Cotoneaster apiculata*-Cranberry Cotoneaster
- *Cotoneaster horizontalis*-Rock Cotoneaster
- *Euonymus americanus*- Strawberry bush
- *Hydrangea arborescens*-Smooth Hydrangea
- *Hydrangea quercifolia* –Oakleaf Hydrangea
- *Hypericum prolificum*-St. John's Wort (native)
- *Ilex crenata*-Japanese Holly
- *Ilex glabra*-Inkberry Holly
- *Ilex verticillata*-Winterberry
- *Itea virginica*-Virginia Sweetspire
- *Juniperus chinensis*-Juniper
- *Juniperus horizontalis*-Wiltion Juniper
- *Juniperus virginiana* – Eastern red cedar
- *Kalmia angustifolia*-Sheep Laurel
- *Kalmia latifolia*-Mountain Laurel
- *Leucothoe fontanesiana*-Drooping Leucothoe
- *Lindera benzoin*-Spicebush
- *Myrica pensylvanica*-Northern Bayberry
- *Philadelphus species*-Mockorange
- *Photinia melanocarpa*-Black Chokeberry
- *Photinia pyrifolia*-Red Chokeberry
- *Physocarpus opulifolius*-Ninebark
- *Pieris japonica*-Japanese Pieris
- *Rhododendron catawbiense*-Hybrid Rhododendron
- *Rhododendron maximum*-Rosebay
- *Rhododendron periclymenoides*-Pinxter Flower
- *Rhododendron PJM*-PJM Rhododendron
- *Rhododendron viscosum*-Swamp Azalea
- [Salix discolor](#) – Pussy willow
- *Sambucus canadensis*-Common Elderberry
- *Sambucus racemose*-Red Berried Elder
- *Spiraea alba* -White Meadowsweet
- *Spiraea tomentosa* - Steeplebush
- *Symphoricarpos albus*-Snowberry
- *Symphoricarpos orbiculatus*°Coralberry
- *Syringa meryeri*-Meyer Lilac
- *Syringa vulgaris*-Common Lilac
- *Taxus cuspidate*-Japanese Yew
- *Taxus media*-Hicks Yew



- *Vaccinium* species-Blueberries
- *Viburnum acerifolium*-Maple-leaved Viburnum
- *Viburnum X burkwoodii*-Burkwood Viburnum
- *Viburnum dentatum*-Arrowwood Viburnum
- *Viburnum lantanoides*-Hobblebush
- *Viburnum prunifolium*-Blackhaw Viburnum
- *Viburnum recognitum*-Southern Arrow-wood

### Ground Covers and Vines

- *Allium cernuum*-Nodding Onion
- *Antennaria neglecta*-Field Pussytoes
- *Arctostaphylos uva-ursi*-Bearberry
- *Carex pensylvanica*-Pennsylvania Sedge
- *Celastrus scandens*-Bittersweet
- *Chelone glabra*-Turtlehead
- *Chrysogonum virginiana*-Green and Gold
- *Clematis* species-Clematis
- *Conoclinium coelestinum*-Blue Mistflower
- *Coreopsis verticillata*-Threadleaf Coreopsis
- *Fragaria virginiana*-Virginia Strawberry
- *Geranium maculatum*-Wild Geranium
- *Heuchera Americana*-Coral Bells
- *Mitchella repens*-Partridge Berry
- *Pachysandra procumbens*-Allegheny spurge
- *Parthenocissus quinquefolia*-Virginia Creeper
- *Penstemon digitalis*-Beard Tongue
- *Phlox stolonifera*-Creeping Phlox
- *Polygonatum*-Solomon's Seal
- *Rhus aromatica* - Fragrant sumac (cultivar 'Lo-Gro' is used as a ground cover)
- *Salvia lyrata*-Lyre-Leaved Sage
- *Sedum ternatum*-Three-Leaved Stonecrop
- *Sisyrinchium angustifolium*-Blue-Eyed Grass
- *Thymus serpyllum*-Creeping Thyme
- *Tiarella cordifolia*-Foam Flower
- *Tradescantia virginiana*-Spiderwort
- *Viola sororia*-Common Blue Violet

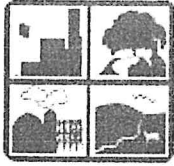

Township of

Planning & Zoning Department

Pennsylvania

**Ferguson Township, Centre County, Pa.  
Application for Zoning Variance/Appeal Hearing**

Application for a Hearing must be filed in the name of the owner of record or in the name of the holder of an option or a contract to purchase, or in the name of the lessee if authorized under a lease.

The application must be completed in full and the following must accompany the application:

1. Thirteen (13) copies of the application.
2. Thirteen (13) copies of a diagram or site plan (as outlined on page 3).
3. For a Variance Hearing a non-refundable filing fee of \$300.00 (make check payable to Ferguson Township).
  - For an Appeal Hearing a filing fee of \$500.00 (make check payable to Ferguson Township). The Appeal Hearing fee is refundable if the applicant prevails in the appeal of a notice of violation.
  - If applying for both a Variance Hearing and an Appeal Hearing both the Variance fee of \$300.00 and the Appeal fee of \$500.00 must be paid to the Township.
4. A copy of the applicant's deed or other instrument showing authority to file this application must be attached.
  - If the instrument attached does not contain a legal description, a legal description must be provided.

All material should be submitted to the Ferguson Township Zoning Office no later than 5:00 PM on the fourth Monday of the month. All incomplete applications will not be processed.

Email zackmaser@yahoo.com

**ENTRY OF APPEARANCE**

Name Zachary Maser

Address 310 Marengo Lane, PA Furnace, PA 16865

I am appearing on my own behalf  (Check if this is true.)

I am representing \_\_\_\_\_

Please send me notice at the above address of any final decisions in this matter.

### WAIVER OF STENOGRAPHIC RECORD

I agree to waive the requirements of Section 908(7) of the Pennsylvania Municipalities Planning Code which requires that a stenographic record of the proceedings be made, and consent that a record of the proceedings be prepared from a tape recording of the hearing and the recording secretary's minutes.

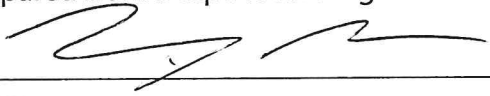
Applicant's Signature   
Date 4/21/21

The undersigned hereby applies to the Ferguson Township Zoning Hearing Board for a hearing under the provisions of the Ferguson Township Zoning Ordinance affecting the following premises in the manner herein described.

Applicant Zachary Maser

Address 310 Marengo Lane, PA Furnace, PA 16865

Phone FAX (814) 883-7754

Owner Zachary and Elizabeth Maser

Address 310 Marengo Lane, PA Furnace, PA 16865

Phone FAX (814) 883-7754

1. Location of premises 310 Marengo Lane, PA Furnace, PA 16865

2. Centre County Tax Map Parcel Number 24-006A, 081-, 0000-

3. Present zoning R-1

4. How long has the applicant held an interest in the property? 38 years

5. Present use of the premises primary residence

6. Proposed use of the premises primary residence with driveway replacement

7. Explain extent of proposed alteration(s), if any: The current driveway is cracked and broken. We will remove the existing driveway and repave a new driveway in its place. one parking spot will be extended by 6 ft on one side to allow ample room for entering and exiting the vehicle parked there.

8. Describe all existing structures, including type size and height: House 70' x 30' x 25'

Utility Shed 12' x 8' x 10'

Driveway 60' x 13' (length) 11' x 46' (parking)

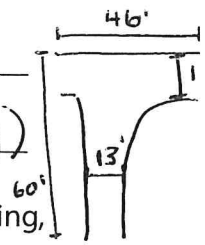

9. Has the property been involved in previous zoning hearing(s)? Yes If so, describe date of hearing, nature of hearing and outcome of hearing:

In 2018, we needed a variance hearing to build an addition on our house. The variance was granted.

10. For new construction or alterations:

- a) Have plans been submitted to the Zoning Officer? Yes. (They are included with this application.
- b) Has he/she reviewed, approved, and signed the plans? No
- c) Has he/she issued a permit? No

11. For a variance hearing, describe the provisions or regulations of the Ferguson Township Zoning Ordinance under which application for a variance is sought:

We would like to replace the existing driveway, which was built with the house. It was built partially in the flood plain.

12. For an appeal hearing, describe the alleged misinterpreted or misapplied provision of the ordinance which will be relieved by granting this appeal:

13. A variance will be granted only upon the showing of an unnecessary hardship meeting all of the following criteria:

- a) The unnecessary hardship is caused by unique physical circumstances in the size, shape or topography of the lot.
- b) Because of the unnecessary hardship so caused, the lot cannot be developed in conformity with the Zoning Ordinance.
- c) The unnecessary hardship was not created by the applicant. a) Key map showing the generalized location of the property.
- d) The variance, if granted, would not alter the essential character of the neighborhood, impair the use or development of adjacent property or be detrimental to the public welfare.
- e) The variance would be the minimum necessary to afford relief and would be the least possible modification of the Zoning Ordinance.

Describe hardship, as listed above, which will be relieved by granting this variance:

As can be seen in the included photographs, the current driveway is deteriorated and in need of replacement. If not repaired, the driveway will continue to deteriorate and we will no longer have a place to park our vehicles.

14. Attach a diagram or site plan showing the following:

- a) Key map showing the generalized location of the property.
- b) North point.
- c) Name and address of all abutting property owners.
- d) Total tract boundaries of the property showing approximate distances and a statement of total acreage of the tract.
- e) All existing streets including streets of record (recorded but not constructed) on or abutting the tract including names and right-of-ways.
- f) If relevant to the application, existing sewer lines, water lines, fire hydrants, utility lines, culverts, bridges, railroads, watercourses, and easements.
- g) All existing buildings or other structures and approximate location of all tree masses.

15. List all abutting property owners. Include full name, address, and telephone numbers

① Jim and Tina Nachtman: 308 Marengo Lane  
PA Furnace, PA 16865  
(814) 235-7897

② Alan Graefe: 4320 West Whitehall Road  
PA Furnace, PA 16865 (814) 237-4345

③ Fairbrook Park

FOR STAFF USE ONLY:

- Plans submitted
- Advertised
- Posted
- Fee Paid

Revised  
09/14/2017



1001 E. College Avenue  
 Bellefonte, PA 16823  
 Phone: (814) 359-3462  
 Fax: (814) 359-3464  
[www.ebypaving.com](http://www.ebypaving.com)

Submitted To	Zach Maser	Contact	Zach	Date	3/16 21
Address 1	310 Marengo Lane	Email	<a href="mailto:zackmaser@yahoo.com">zackmaser@yahoo.com</a>	Work Phone	
Address 2		Mobile Phone	883 7754	Fax	
City, State, Zip	PA Furnace, PA 16865	Job Name			
Plans	Job Location				

We hereby submit specifications and estimates for:

**Proposal:**

- 1 Mobilize to site.
- 2 Remove existing asphalt, add 2A stone as needed, shape for drainage, finegrade and compact.
- 3 Provide and place 2.5" (compacted depth) of 9.5mm wearing course.

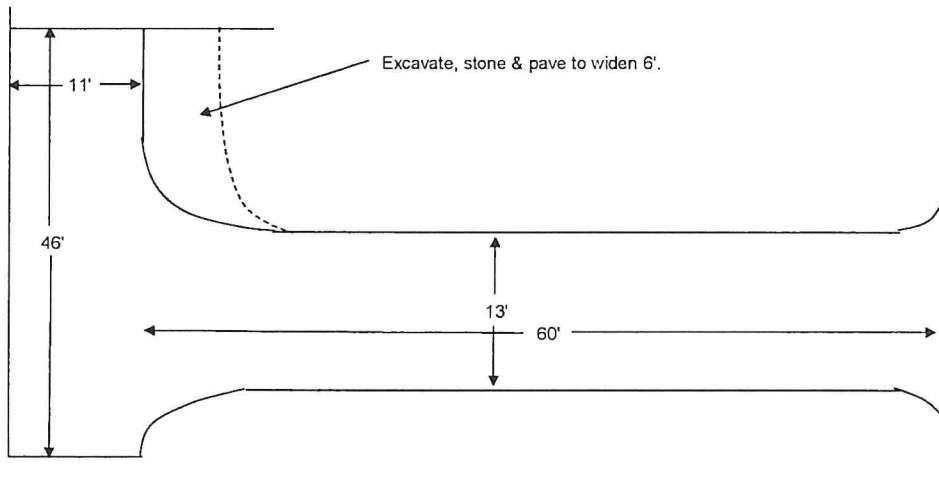

\*Note - Based on condition of driveway stone base may not be suitable for paving, if so, price may increase by no more than \$1995.00

\*Note - Based on lack of slope there may be some puddling of water.

**Notes**

- 1 Permit (if required) is the responsibility of the customer. Check with your local municipality.
- 2 Be sure to check out [www.ebypaving.com](http://www.ebypaving.com) for more information about EBY Paving & Construction, Inc.

We Propose hereby to furnish material and labor - complete in accordance with specifications below, for the sum of:

Six thousand eighty dollars ( \$6,080.00 )

Payment to be made as follows: Within 10 days after completion of work. 1.5% interest added per month.

All material is guaranteed to be as specified. All work to be completed in a workmanlike manner according to standard practices. Any alteration or deviation from the specifications below involving extra costs will be executed only upon written orders, and will become an extra charge over and above the estimate. All agreements contingent upon strikes, accidents or delays beyond our control. Owner to carry fire, tornado and other necessary insurance. Our workers are fully covered by Workman's Compensation Insurance.

Authorized Signature *Thomas W. Moran*

Estimator Thomas W. Moran

This proposal may be withdrawn by us if not accepted within: 30 days.

**Acceptance of Proposal** - The above prices, specifications and conditions are satisfactory and are hereby accepted. You are authorized to do the work as specified. Payment will be made as outlined above. To accept proposal, sign and return one copy.

Signature *E. Moran*

Date 3/23/21

Signature *Zach Maser*

Date 3/23/21

# CENTRE REGION COUNCIL OF GOVERNMENTS

2643 Gateway Drive, Suite 3

State College, PA 16801

Phone: (814) 231-3077 Fax: (814) 231-3083 Website: [www.crcog.net](http://www.crcog.net)

---

## EXECUTIVE COMMITTEE

Video Conference

April 20, 2021

12:15 PM

### GENERAL MEETING INFORMATION

**STEP #1:** [Click HERE to RSVP and REGISTER for the meeting via ZOOM](#)

After you RSVP, a link to register via Zoom will be shown. Click to register.

Once registered, you will receive a confirmation email containing information about joining the meeting.

**STEP #2:** [Click HERE to locate the AGENDA and ATTACHMENTS](#)

Should you desire to annotate any attachments you must download them first.

**To attend this meeting by phone: +1 929 205 6099 | Meeting ID: 871 9514 3034**

**Meeting Contact:** Scott Binkley ([sbinkley@crcog.net](mailto:sbinkley@crcog.net), 814-235-7818)

- This meeting will be recorded, and electronic files of the meeting will be made available on the COG website upon its conclusion.
- We ask that non-voting participants remain muted with their video turned off unless recognized or are actively speaking. To reduce audio interference, please remain off speakerphone during the meeting.
- **VOTING PROCEDURES:** Members will provide their vote by voice. Clarification will be sought by the Chair if the vote is unclear. Members opposed to a motion should vote “No”. For additional information on COG Voting Procedures, please click [HERE](#).
- **PUBLIC COMMENT GUIDELINES:** Members of the public may comment on any items not already on the agenda (five minutes per person). Comments relating to specific items on the agenda should be deferred until that point in the meeting. For additional information on COG public meeting guidelines, please click [HERE](#).
- To access agendas and minutes of previously held meetings, and to learn more about the COG Executive Committee on our website, please click [HERE](#).

# CENTRE REGION COUNCIL OF GOVERNMENTS

2643 Gateway Drive, Suite 3  
State College, PA 16801  
Phone: (814) 231-3077 Fax: (814) 231-3083 Website: [www.crcog.net](http://www.crcog.net)

---

## EXECUTIVE COMMITTEE

Video Conference  
April 20, 2021  
12:15 PM

During the COVID-19 health emergency, to continue business operations of the COG and ensure the safety of municipal officials and staff, and to adhere to health emergency recommendations while remaining in compliance with Pennsylvania's guidelines for public meetings, this Executive Committee meeting will be held via video conference. Written public comment or requests to speak to the Executive Committee for items not on the agenda, and requests to comment to specific agenda items listed below, may be submitted in advance by emailing [sbinkley@crcog.net](mailto:sbinkley@crcog.net).

## AGENDA

1. CALL TO ORDER AND ROLL CALL

Mr. Hameister will convene the meeting. Mr. Binkley will take a roll call of members.

2. PUBLIC COMMENTS

Members of the public are invited to comment on any items not already on the agenda (five minutes per person time limit please). Comments relating to specific items on the agenda should be deferred until that point in the meeting. Submitted comments will be read into the record by the Recording Secretary at the appropriate time in the meeting.

3. APPROVAL OF MINUTES

A copy of the minutes of the March 16, 2021 Executive Committee meeting are **enclosed**.

4. COG MEETING ETIQUETTE - Presented by Eric Norenberg

Background

The General Forum has made a commitment to an environment in which all individuals are treated with respect and dignity. The COG Meeting Etiquette guidelines adopted in 2018 declare that everyone has the right to participate in a professional atmosphere that promotes equal opportunities to be heard and to participate in the decision-making



process. Because it is important that meetings are conducted efficiently so the time that people invest at meetings is well spent and concludes within a reasonable timeframe, it is important that each participant respect each other, as well as the Chair, and their role in facilitating the expeditious conduct of business. Accordingly, in the past, these requests were made:

- Participants were asked to adhere to and support the COG Etiquette Guidelines.
- Participants were asked to mute themselves when not actively speaking and non-voting participants were asked to turn off their video unless recognized to speak.
- To maintain a respectful and orderly process, elected officials, and members of the public seeking to speak to specific agenda items were asked to use the electronic “raise hand” feature in Zoom to be recognized by the Chair when appropriate.

### Discussion

In response to feedback received from General Forum members and others to strengthen and support these guidelines and requests, staff proposes to take the following steps during upcoming General Forum meetings:

**Muting and Unmuting of Meeting Participants:** During the meeting, all participants should be muted unless recognized to speak. Should an individual desire to speak they must raise their electronic hand or indicate to a meeting host by way of chat that they wish to speak. Should audio cause disruption to the meeting please note that staff will work to mute these participants.

**Chat Feature:** The chat feature will be limited to discourage sidebar conversations during the meeting. Participants will only be able to send chat messages to meeting hosts. If presenters have links or other information to share with the group, it can be provided to the host and distributed after the meeting.

**Speaker Management:** Assigned persons will work to manage the time provided for with comment by elected officials and members of the public to ensure that equal time and participation is provided for, in accordance with COG meeting guidelines.

More information, including frequently asked questions and guidelines for public comment, can be found on the COG’s website at [www.crcog.net](http://www.crcog.net).

The Executive Committee is asked to provide any feedback or suggestions regarding the preceding strategies.

## 5. MOTION CLARIFICATION PROCESS – Presented by Eric Norenberg

Occasionally during meetings members may move motions or amend existing motions. At times, these motions may become complex and require clarification before a vote is taken. It is important that clarification be provided, nor any assumptions made that clarity exists.

The COG Articles of Agreement state:

*ARTICLE V – ORGANIZATION*

*F. Rules of Order: Any matter pertaining to the conduct of any meeting and the procedures thereof shall be governed by the latest edition of Roberts' Rules of Order.*

It is crucial that every member of the group knows and understands what they are voting on. Roberts' Rules of Order specify that a responsibility of the meeting Chair is to clarify motions. However, all General Forum members and staff should feel encouraged to seek clarity on the motion if it does not exist.

**Steps to Clarify A Motion:**

**Making a Motion:** A motion and a second should be made prior to discussion of the item by the General Forum.

**Reread the Motion:** Before a vote is taken, the Chair should either reread the motion or ask that the maker of the motion repeat the motion. This enables the recording secretary to accurately record it and for the audience and membership to hear it clearly and know what is being voted upon. Should the motion be clear to the recording secretary, they may also reread the motion or ask that the maker of the motion repeat the motion for clarity if needed.

**Clarify What the Vote Means:** If the motion is confusing or complicated, it is best to explain what a "yes" vote or a "no" vote means. Often this is self-explanatory, but if there are doubts, the Chair should clarify beforehand. This is specifically important for complicated procedural votes.

**Clarify the Motion:** If the Chair believes a motion is unclear, it can be requested that the maker of the motion suggest modification or clarification to the wording. The Chair should confirm with the individual who seconded the motion that there is agreement, and that the intent has not changed.

6. **APPROVAL OF GENERAL FORUM AGENDA ITEMS** – Presented by Eric Norenberg

The Executive Committee is asked to support including the following items on the April 26, 2021, General Forum agenda:

**Strategic Plan Update / Review Draft Mission, Vision, and Values:** In early January, the COG, with the support of Penn State University, began to develop a strategic plan intended to guide the work of the COG over the next five to ten years. This process started with a survey of COG staff. These results were analyzed, packaged into draft mission and vision statements, and a list of values that were sent to elected officials for input. After the input from elected officials, the revised draft mission and vision statements and values were discussed with the COG Agency Directors. Directors provided additional feedback that assisted with revisions, and this guided an additional survey to COG staff.

During the General Forum meeting, a presentation and facilitated discussion by elected officials will help move towards selecting the final mission and vision statements as well as final values for the COG strategic plan. The next steps will be the development of goals, objectives, strategies, and tactics based on the finalized parts of the COG strategic plan.

**Update by the Solar Power Purchase Agreement Working Group:** This agenda item asks for time on the General Forum agenda for Peter Buck and Gretchen Brandt to present an update on the Solar Power Purchase Agreement Working Group's (SPPA WG) activities, which includes the planned release for a Request for Proposals (RFP) for an Energy Services Consultant in May. Mr. Buck and Ms. Brandt will review how this project aligns with the regional Climate Action and Adaptation Plan (CAAP).

The Executive Committee is requested to briefly discuss and provide guidance regarding including both items on the April 26, 2021, General Forum agenda.

7. **RESOLUTION 2021-4 TO DESIGNATE MAY AS BIKE MONTH** – Presented by Trish Meek

This item provides information on biking and pedestrian activities in the Centre Region and asks that the Executive Committee forward a resolution to the General Forum as recommended by the Public Services and Environmental Committee and the Transportation and Land Use Committee recommending that May 2021 be designated as Bike Month. The resolution should be forwarded from the Executive Committee to the General Forum for final action at its April 26, 2021 meeting.

Bicycling and walking activities continue to grow in popularity and importance in the Centre Region, and all the Region's municipalities are actively engaged in planning and implementing projects to facilitate bicycling and walking.

The COG applied in October 2020 to the League of American Bicyclists for designation as a Bicycle Friendly Community on behalf of the Centre Region municipalities. The application recognized the importance of bicycling and walking and the expanding nature of the Region's network of bike and pedestrian facilities. Based upon the strength of the application, the Centre Region was elevated to a silver-level Bicycle Friendly Community in December 2020.

COG staff is requesting that Resolution 2021-4 **enclosed** be adopted by COG designating May 2021 as Bike Month. The resolution also recognizes May 17 to 23, 2021 as Bike to Work Week, and May 21, 2021, as Bike to Work Day and Centre Region Bike Anywhere Friday. A draft resolution is enclosed for consideration by the committee.

These bike designations would complement the activities of the individual municipalities and COG in planning and implementing projects and programs that support bicycling and walking in the Region. The League of American Bicyclists also awarded the Bicycle Friendly Business designation to the State College Borough and the CROG in 2021.

These awards are indicative of the progress being made to expand the role of bicycling and walking in the community. To continue the effort to raise awareness of these modes of

transportation, staff requests that the Executive Committee forward the PSE/TLU Committee recommendation to the General Forum for consideration and adoption of draft resolution 2021-4.

*“That the Executive Committee as recommended by the PSE and TLU Committees recommend that the General Forum receive and approve Resolution 2021-4, designating May 2021 as Bike Month, May 17 to 23, 2021 as Bike-to-Work Week, and May 21, 2021, as Bike to Work Day and Bike Anywhere Friday in the Centre Region.”*

**All municipalities should vote on this motion.**

8. BUDGET AMENDMENT – A/V SYSTEM – Presented by Eric Norenberg and Joe Viglione

The Facilities and Finance Committees have recommended a budget amendment to upgrade the A/V System in the General Forum Room. The Executive Committee is asked to consider the recommendation and to decide if a recommendation to the General Forum is appropriate.

At its April 6, 2021 meeting the Facilities Committee discussed options to upgrade the Audio/Visual system in the General Forum Room to improve the sound quality in the room and create a pathway forward that will allow the General Forum and COG Committees to conduct meetings successfully in a hybrid manner. The Facilities Committee discussed the Facilities Coordinator’s recommendation of:

COG: Base Install - Minimum Equipment (\$31,251.00)

*This base installation will utilize OFE (owner-furnished equipment) along with supplemental equipment for expanded functionality. The central element of the system shall be the Q-SYS Core 110F. This processor will handle all audio and control signals for the system. 2 Shure MXA910 ceiling microphone arrays shall be mounted over the central portion of the space to cover the entire room with 16 channels of steerable audio. A single PTZ camera shall be mounted at the rear of the room and can be controlled via IR remote or via the included touch panel. The I/O USB Bridge shall serve as the distribution point for room audio and camera video to a USB host (laptop) for remote participants. Audio will also be ingested from remote participants through this connection and distributed to the room audio system via the Q-SYS Core. The Q-SYS NV-32H shall distribute the existing video signals from the room system to the projectors, while also allowing HDMI signal from the laptop to be shared as well. Accessibility for the hearing impaired shall be provided through the Williams Sounds FM557 Pro unit. This unit allows for an unlimited number of receivers to be added. Included in the system are 4 wireless receivers with 4 sets of headphones and 2 personal neck loops (for induction loop capable devices). A traditional induction loop for the room is not recommended due to the infrastructure requirements for such a large room that are not currently in place (based on consultation from 2 separate induction loop manufacturers).*

COG: Add-Alt 2 - Polycom Eagle Eye Director II (\$15,575.00)

*This add-alt removes the base PTZ cameras and replaces them with a Polycom Eagle Eye Director II system. This system is comprised of a base unit (G7500) that will be configured to operate as a zoom room. 2 Polycom Eagle Eye Director II cameras will be cascaded to work together from the rear and side of the room. This will allow for seamless camera positioning and switching without a camera operator. By using*

the G7500, you will also have the ability to manually control the PTZ functionality of these cameras for fixed presentations. These cameras can be used without the G7500 - but they would be locked in the “auto-tracking” mode.

In addition, the Committee authorized a contingency on the project bringing the total budget amendment to \$48,000, on a not to exceed basis funded through a budget amendment. The motion passed by the Facilities Committee is as follows:

*“That the Facilities Committee recommends to the Finance Committee and Executive Committee that a budget amendment be authorized in the amount of \$48,000 in the COG Building Capital Budget to upgrade the A/V system in the General Forum Room.”*

While not specifically recommending a funding mechanism, the Facilities Committee encourages the municipalities to consider contributing a portion of their American Rescue Plan Act funding to offset the cost. If the utilization of these funds is not determined to be a viable option, the replenishment of these funds should be considered in conjunction with the development of the 2022 COG Budget.

During their April 8, 2021 meeting the Finance Committee approved the following motion:

*“That the Finance Committee as recommended by the Facilities Committee, recommends that the Executive Committee and General Forum approve that a budget amendment be authorized in the amount not to exceed \$48,000 in the COG Building Capital Budget to upgrade the A/V system in the General Forum Room.”*

Further background information can be found in the **enclosed** documents. Should Executive Committee members agree, the following motion could be considered to move the recommendation on to the General Forum for approval in accordance with the COG policy for budget amendments:

*“That the Executive Committee, as recommended by the Facilities and Finance Committees recommend that the General Forum approve that a budget amendment be authorized in the amount not to exceed \$48,000 in the COG Building Capital Budget to upgrade the A/V system in the General Forum Room.”*

**All municipalities should vote on this motion.**

9. COVID-19 LEAVE REPLACEMENT - Presented by Eric Norenberg

In 2020, the Families First Coronavirus Response Act (FFCRA) required employers to provide emergency paid sick leave and emergency family medical leave. As you may recall, COG provided more leave than the law required. When the policy expired on December 31, 2020, we continued to roll any remaining COVID emergency sick leave balances through the first quarter of 2021 as we waited for more federal guidance or new legislation. While a number of COG staff still had remaining balances of emergency leave, many did not.

The American Rescue Plan Act (ARPA) **enclosed** is legislation that was approved in March and makes emergency paid sick leave optional for employers but provides an incentive for those employers that offer the emergency paid sick leave. The incentive is a tax credit to offset the cost of the emergency paid sick leave when used for approved purposes for an employee, and two-thirds of the cost when used for an approved purpose for a household or family member.

Staff presented information about the ARPA Emergency Paid Sick Leave program to the Human Resources Committee on April 7. The Committee was supportive. Because of the benefit to the health and safety of our employees, the COG Executive Director implemented the ARPA Emergency Paid Sick Leave program retroactive April 1 to replace the original emergency COVID-19 leave program in time for the payroll that included the effected date of the program. A new administrative policy provided all regular full-time employees with a fresh balance of 80 emergency paid sick leave hours, while all regular part-time employees are entitled to a prorated amount. The provisions of the policy will expire on September 30, 2021, unless otherwise extended by federal legislation.

The policy also includes a revised list of reasons in which emergency paid sick leave and family medical leave can be used, as well as new tracking/documentation requirements that will enable COG to obtain tax credits to reimburse the use of the leave. In addition, the COG is still offering the Negative Leave Accrual program **enclosed** for those employees that may need it.

Later, after the Human Resources Committee meeting, staff learned about one aspect of the program after that Committee presentation. At the time, it was understood that tax credits could cover 100 percent of the cost of the leave time (up to 80 hours). It is now understood that the tax credits will cover 100 percent of the leave time for employees. However, when an employee uses the emergency leave for an approved purpose for a household or family member, only two-thirds of the time will be reimbursed by the tax credits. (It should be noted that none of the prior COVID-19 Leave programs were reimbursed by any federal or state program. According, this new program will cost much less than allowing staff to carry and use the old leave balances that were not eligible for any tax credits.)

The Executive Committee is requested to endorse the Executive Director's decision and authorize participation in the voluntary ARPA Emergency Paid Sick Leave program with the following motion:

*“That the Executive Committee endorses the Executive Director implementation of the ARPA Emergency Paid Sick Leave program as a replacement for the 2020 COVID-19 Leave program, retroactive to April 1, 2021.”*

**All municipalities should vote on this motion.**

10. APPOINTMENT OF COG SOLICITOR DISCUSSION – Presented by Eric Norenberg



This item proposes that the Executive Committee begin a discussion regarding the appointment of the COG solicitor, as was recommended during the February 16, 2021, Executive Committee Meeting.

*Article V of the COG Articles of Agreement, item C states:*

***Solicitor:*** *The Centre Region COG General Forum shall appoint a solicitor, who shall be the chief consultant of the Centre Region COG in all legal matters.*

The responsibility to appoint a solicitor by the General Forum first appears in the COG Articles of Agreement as signed on October 23, 1989.

The then-COG solicitor was in place prior to that responsibility being added to the Articles of Agreement and before the hiring of former Executive Director, Jim Steff. At that time, the COG solicitor was John R. Miller Jr., of the same firm that current COG solicitor Terry Williams represents. Mr. Miller provided his services to the COG until 2007 when due to illness, Mr. Williams was chosen to succeed him because of his knowledge and understanding of COG.

The COG Purchasing Policy and Procedures note that while “*applicable state procurement laws do not require the bidding of professional/consulting services such as legal, accounting, engineering, auditing, insurance, medical, and architectural services*” at “*times, it may be in the best interest of the Centre Region Council of Governments to retain a professional consultant for a multi-year contract period (such as for legal or auditing services). In these cases, a contract not exceeding a three (3) year term may be awarded by the governing body using the RFP process.*”

Since there is no additional guidance in the COG Articles of Agreement as to how the COG solicitor is selected and appointed, nor any directive regarding the frequency of appointment, the Executive Committee may discuss preferences regarding the selection process for retaining the COG solicitor.

11. COMMUNICATIONS PROCEDURE TO OUTSIDE ENTITIES – Presented by Eric Norenberg

This item asks that the Executive Committee begin a discussion regarding the following recommendation as provided during the February 16, 2021, Executive Committee Meeting:

*Create a procedure to provide a framework and guidance for COG committees proposing to send advocacy letters to other governments or agencies, to submit feedback or opinions as a result of requests from other local, state, or national organizations, to release surveys to the public, or submit opinion columns to publications or other media.*

The Executive Committee is asked to discuss and determine what type of communication should require prior approval of the Executive Committee and/or General Forum before being transmitted to entities outside of COG. The following are items for the Executive Committee to consider and discuss.

Consideration should be given to the following factors:

- Urgency and timeliness of the matter – Are there critical due dates or timeliness constraints driven by external factors (e.g., legislative calendars)?
- Specificity of the topic – i.e. Is the topic highly focused on the responsibility of a given COG Committee or Agency? Or is it one that crosses more than one Committee’s areas of responsibility?
- Is it appropriate for the COG to speak for the Centre Region and its municipalities on the topic? - Or do municipalities have conflicting opinions?
- Is it a routine matter?

Possible review and approval steps to be coordinated by the Committee Chair, Executive Director, and Agency Director:

- Consensus is obtained from the Committee – Either through vote during a meeting or review of a draft document via email.
- Review by the COG Chair – For urgent matters, the COG Chair could review and approve being sent prior to review by the Executive Committee.
- Review and approval by the Executive Committee.
- Final review and approval by the General Forum, if determined necessary by the Executive Committee.

After discussion, the Executive Committee is asked to provide direction to staff on the type of communication that should be required before the approval of the Executive Committee and/or General Forum, the role for the Committee Chair, the COG Chair, and the Executive Director to play in guiding the process and deciding next steps, and, if possible, what items should be reviewed by the full Executive Committee and under what circumstances. With this guidance, a draft procedure can be prepared for consideration during the April Executive Committee meeting.

## 12. EXECUTIVE DIRECTOR’S REPORT

The Executive Director will update the Executive Committee on other items of current interest.

## 13. OTHER BUSINESS

- A. Matter of Record – The next meeting of the Executive Committee is scheduled for Tuesday, May 18, 2021, at 12:15 PM. It has not yet been determined if this will be an in-person or video conference meeting.
- B. Matter of Record – The standardization of the COG employment application remains a work in progress. Currently, we are working with Schlow IT staff to help us develop the application in an online format.
- C. Matter of Record – The Work From Home policy was presented to the General Forum on Monday, March 22, 2021. The policy was adopted by the General



Forum with the understanding that further guidance would be sought from COG's labor attorney regarding potential OSHA (Occupational Safety & Health Administration) liabilities.

The attorney noted that the entire home is not considered the remote workplace, only the *designated* workspace within the home. She also advised that while OSHA does have good standards to follow, OSHA does not have jurisdiction over municipal entities/local governments. Therefore, injuries that occur during work from home scenarios would be a Workers Compensation matter for the COG, rather than an OSHA concern. COG's labor attorney feels the Work From Home policy, agreement, and safety checklist are best business practices and sufficient with regards to safety and reporting any injuries that may occur while working from home.

14. CALENDAR

A calendar with upcoming COG committee, General Forum, and municipal meetings can be found by clicking the following link: [COG and Municipal Meeting Overlay Calendar](#)

15. ADJOURNMENT

ENCLOSURES

<u>Item #</u>	<u>Description</u>
03	Executive Committee Meeting Minutes: March 16, 2021
07	Resolution 2021-4 to Designate May as Bike Month
08A	General Forum Room Background and Supporting Documentation
08B	Dobil Laboratories - Centre Region COG Main Meeting Room Hybrid
09A	American Rescue Plan Act - Emergency Leave & FMLA
09B	Negative Leave Accrual Procedures

# Centre County Metropolitan Planning Organization (CCMPO) Coordinating Committee Meeting

Tuesday, April 27, 2021  
6:00 p.m.

## MEETING INFORMATION

Please refer to the links below to **REGISTER** to attend the meeting via Zoom and to **LOCATE** the agenda and attachments.

[CLICK here to register to attend the meeting via Zoom](#)

After registering you will receive a confirmation e-mail from Centre Regional Planning Agency containing information about attending the meeting via Zoom.

[CLICK here to locate the AGENDA and ATTACHMENTS](#)

---

<p><b>To attend this meeting via phone:</b> <b>+1 301 715 8592   Meeting ID 876 2228 2416   Passcode: 103554</b></p>
--

Meeting Contact: Marcella Laird ([mlaird@crcog.net](mailto:mlaird@crcog.net) - 231-3050)

This meeting and the group chat will be recorded and both video and audio files of the meeting will be made available on the COG website upon its conclusion.

- We ask that non-voting participants remain muted with their video turned off unless recognized or are actively speaking. To reduce audio interference, please remain off speakerphone during the meeting.
  - **VOTING PROCEDURES:** Members will provide their vote by voice. Clarification will be sought by the Chair if the vote is unclear. Members opposed to a motion should vote “No”.
  - **PUBLIC COMMENT GUIDELINES:** Members of the public may comment on any items not already on the agenda (five minutes per person). Comments relating to specific items on the agenda should be deferred until that point in the meeting.
  - To access agendas and minutes of previously held meetings, and to learn more about the CCMPO on our website, please click [HERE](#).
-

# Centre County Metropolitan Planning Organization (CCMPO) Coordinating Committee Meeting

Tuesday, April 27, 2021

6:00 p.m.

***VIRTUAL MEETING VIA ZOOM***  
***PLEASE CONTACT [MLAIRD@CRCOG.NET](mailto:mlaird@crcog.net) FOR LINK***

Written public comments or requests to speak to the Coordinating Committee regarding items on the agenda, or items not on the agenda, may be submitted in advance by emailing Marcella Laird at [mlaird@crcog.net](mailto:mlaird@crcog.net).

## AGENDA

1. **Call to Order**
2. **Approval of Minutes:** *February 23, 2021 Coordinating Committee meeting.*
3. **Public Comments:** *For items not on the agenda.*
4. **2021-2024 Centre County Transportation Improvement Program (TIP):**  
TIP Revisions – Route 26/45 Intersection Safety Project  
*Action: Approve amendment*
5. **U.S. Census Bureau – Federal Register Notice:**  
Proposed criteria to designate urban areas for the 2020 Census  
*Action: Authorize staff to submit comments*
6. **Transportation Funding Initiatives:**
  - a. **Federal discretionary funding (member designated projects) requests**  
*Action: Endorse the submission of candidate projects*
  - b. **PennDOT Pathways Initiative:**  
*Action: Discussion about potential options for generating state revenue for transportation*
7. **Performance Based Planning and Programming:**
  - a. **CATA and Centre County Office of Transportation – Transit Asset Management (TAM) targets**  
*No action required (action to approve targets will be required in June 2021)*
  - b. **CATA – Public Transportation Safety Performance Measure targets**  
*No action required (action to approve targets will be required in June 2021)*
8. **PennDOT Project Update:**  
Status report from PennDOT District 2-0 about highway and bridge projects  
*No action required*
9. **State College Area Connector (SCAC) Project:**  
Status Report  
*Action: Provide comments to PennDOT*
10. **CCMPO Safety Subcommittee:**  
Status report about safety subcommittee activities  
*No action required*
11. **Member Reports:**  
Reports from members about a significant item(s) of interest  
*No action required*
12. **Announcements**
13. **Adjourn**

*Next Coordinating Committee meeting:  
**June 22, 2021**  
6:00 p.m.  
Anticipated virtual meeting via Zoom*

**CENTRE COUNTY METROPOLITAN PLANNING ORGANIZATION (CCMPO)  
COORDINATING COMMITTEE**

**Tuesday, February 23, 2021**

**6:00 p.m.**

**Virtual Meeting via Zoom**

**Minutes**

**Voting Members**

Eric Bernier	College Township
Theresa Lafer	State College Borough
Frank Harden	Harris Township
Lisa Strickland	Ferguson Township
Pamela Robb	Patton Township
Barbara Spencer	Halfmoon Township
Mark Higgins	Centre County Board of Commissioners
Michael Pipe	Centre County Board of Commissioners
Doug Johnson	Nittany Valley Planning Region
David Veneziano	Lower Bald Eagle Valley Planning Region
Dick Decker	Penns Valley Planning Region
Ken Hall	Mountaintop Planning Region
Keith Reese	Upper Bald Eagle Valley Planning Region
Jon Eich	Centre Regional Planning Commission (CRPC)
John Spychalski	Centre Area Transportation Authority (CATA)
Tom Zurat	PennDOT District 2-0
Larry Shifflet	PennDOT Central Office

**Non-Voting Members**

Rob Cooper	The Pennsylvania State University (PSU)
Matt Smoker	Federal Highway Administration (FHWA)
Chelsea Beytas	Federal Transit Administration (FTA)

**Others Present**

Tom Zilla	Centre Regional Planning Agency (CRPA)
Jim May	CRPA
Trish Meek	CRPA
Greg Kausch	CRPA
Pam Adams	CRPA
Marcella Laird	CRPA
Anne Messner	CCPCDO
Frank Hampton	PennDOT Central Office
Louwana Oliva	CATA
Dean Ball	PennDOT District 2-0
Mark Long	Representative Benninghoff's Office
Matt Wise	Senator Corman's Office
Ford Stryker	Ferguson Township Resident
Ann Glaser	Centre County Resident

**1. Call to Order**

Mr. Bernier called the meeting to order at 6:00 p.m. and turned the floor over to Mr. Kausch, who provided an overview of the meeting procedures, which included directions for how to participate in the meeting and access the agenda.

## 2. Election of Officers

Mr. May opened the floor for nominations for the Coordinating Committee Chair, Vice-Chair, and Secretary.

*Motion was made by Ms. Lafer, seconded by Mr. Johnson to nominate Mr. Bernier for the 2021 Coordinating Committee Chair, Mr. Pipe for the 2021 Coordinating Committee Vice-Chair, and Mr. May for the 2021 Coordinating Committee Secretary. No other nominations were made. The motion carried 17-0.*

## 3. Approval of Minutes

*Motion was made by Mr. Spychalski and seconded by Mr. Higgins to approve the minutes of the November 24, 2020 Coordinating Committee meeting, as presented. The motion carried 17-0.*

## 4. Public Comments

There were no comments from the public.

## 5. Special Announcement

Mr. Bernier announced that on February 19, 2021, Ms. Rusnak, PennDOT District 2-0 Transportation Planning Manager, retired after over 34 years of service. Mr. Bernier stated that in 2019, Ms. Rusnak was honored with PennDOT's Star of Excellence Award. At that time, the CCMPO staff noted that Ms. Rusnak is recognized in District 2-0 and across Pennsylvania for her skill in administering the Transportation Improvement Program, which has resulted in great benefit to the MPOs and RPO in District 2-0. Regularly, District 2-0 and its MPOs and RPOs received additional funding for projects and programs because of Ms. Rusnak's ability to manage financial resources adroitly and creatively.

Beyond the skill that Ms. Rusnak exhibited in managing financial resources, she collaborated with the Centre and SEDA-COG MPOs and the North Central RPO with great enthusiasm, leading to the development of a cooperative working relationship that delivered many projects that benefit the traveling public. Ms. Rusnak's willingness to work closely with the MPO and RPO staffs has been a hallmark of District 2-0's efforts for 30 years. On behalf of the CCMPO Technical and Coordinating Committees and staff, we thank Ms. Rusnak for her outstanding dedication and resulting success, and we wish her the best of luck as she retires to focus on her family and other interests!

## 6. PennDOT Pathways Initiative

The Coordinating Committee received a presentation from Mr. Shifflet regarding the PennDOT Pathways Initiative that was announced by PennDOT on November 18, 2020. This new initiative will examine possible near and long-term options for addressing the \$8.1 billion gap in annual highway and bridge transportation funding that is needed to keep the network in a state of good repair. Mr. Shifflet explained that PennDOT has conducted a Planning and Environmental Linkages (PEL) Study to determine possible alternative funding options. Mr. Shifflet communicated that the alternative funding solutions that were derived from the PEL Study include bridge tolling, managed lanes, congestion pricing, corridor tolling, road user charges, and fee and tax increases. In the spring of 2021, PennDOT will hold a public comment period of the final evaluation of the alternative funding solutions. Mr. Shifflet encouraged Committee members to visit the PennDOT Pathways website where members can learn more about the specific alternative funding solutions. *The entire Pathways presentation can be found on the CCMPO's website under CCMPO Committees - Presentations.*

In response to a question from Mr. Pipe regarding the approval process for the nine candidate bridges, Mr. Shifflet explained that the Public-Private Partnership (P3) Board, which includes legislative staff, industry members, and budget representatives, will approve the proposed candidate bridges based on specific guidelines.

Mr. Hall expressed his concern regarding the deficit in funding and stated that gas mileage gets better on newer cars and more and more electric vehicles are being used with no mechanism for electric vehicles to contribute to taxes to pay for infrastructure. Mr. Eich agreed and stated that road user charges should be given high

priority so that the state can capture the shift from gas to electric vehicles. He went on to say that most commercial fleet vehicles already track their mileage, so it would make sense to start there, especially because there is no additional equipment needed to capture that mileage. Mr. Shifflet responded and stated that the Pennsylvania legislation, along with PennDOT, has discussed legislation to tax electric vehicles, however, no legislation has been passed yet.

In response to a question from Mr. Eich, Mr. Shifflet explained that PennDOT hopes to implement bridge tolling for the 9 candidate bridges in late 2022, but most likely will take place in 2023 as PennDOT needs to gather input on the impacts bridge tolling may have on different communities. He went on to say that in most cases, tolling would begin right before or during the bridge construction to collect the funding needed to pay for the bridge repairs.

Ms. Lafer expressed the importance of finding a mechanism, such as vehicle miles traveled (VMT), to close the funding gap and to ensure that everyone pays their fair share of taxes, sooner rather than later. In addition, she stated that the funding that is collected from the bridge tolling initiative needs to be dedicated specifically for the bridge that it is collected from.

Mr. Harden communicated that from Mr. Shifflet's presentation, it seems that car manufacturers plan to have all electric vehicle models by 2035, so it is important to figure out how to recoup taxes from electric vehicles now rather than later. He suggested that the Coordinating Committee make a policy statement about this issue.

## **7. State College Area Connector (SCAC) Project Update**

The Coordinating Committee received an update on the timeline of the State College Area Connector (SCAC) Planning and Environmental Linkages (PEL) Study. PennDOT finalized the SCAC Purpose and Need document after receiving comments from residents, municipalities, and cooperating and participating agencies through the virtual public meeting and comment period in late 2020. After the Federal Highway Administration (FHWA) approves the final Purpose and Need document, PennDOT will begin creating a methodology for developing alternatives to meet the Purpose and Need of the SCAC project. In May and July, PennDOT will present its methodology for developing the range of alternatives, as well as the alternatives analysis during the Agency Coordination Meeting (ACM). In August, PennDOT will hold a public meeting to present and receive comments regarding the possible alternatives to meet the Purpose and Need. PennDOT intends to have a live interaction meeting to be able to answer questions and address comments in real time. After the public comment period concludes, PennDOT will present possible future projects to meet the Purpose and Need for the SCAC project to move into the National Environmental Policy Act (NEPA) phase.

## **8. Performance Based Planning and Programming**

### **a. Annual Update of PM1 Safety Performance Measure Targets**

The Coordinating Committee received a presentation from Ms. Anne Messer, Centre County Planning and Community Development Office Senior Transportation Planner, regarding PennDOT's 2021 PM1 Safety Performance Measure Targets. The CCMPO supported PennDOT's initial targets for 2018 as well as the targets in the annual updates for 2019 and 2020 because the MPO does not have the staff resources and technical capacity to establish and monitor its own quantifiable targets. Ms. Messner reviewed the 2021 targets and noted that the fatality number listed in 2019 is correct.

In response to a question from Mr. Harden regarding the number of fatalities in 2020, Ms. Messner stated that she does not have any of that data yet. Mr. Zurat added that the accident data for 2020 is not completely accounted for; however, Mr. Zurat can get the most up to date data regarding fatalities in Centre County. Mr. Smoker explained that PennDOT has to submit the data to the FHWA by June of 2021 to have the data certified.



With no further comments or discussion, *motion was made by Ms. Spencer and seconded by Ms. Lafer to select the option to plan and program projects that contribute toward the accomplishment of the statewide PM1 safety targets. The motion carried 17-0.*

**b. Adjustment to PM3 Travel Time Reliability Performance Measure Targets**

The Coordinating Committee received a report from Mr. Zilla regarding an adjustment to PennDOT's PM3 Travel Time Reliability Performance Measure Targets. He explained that in September 2020, PennDOT submitted a required Mid-Performance Period Progress Report to the FHWA for the PM2 and PM3 performance measures. Based on the data collected and documented in the report, PennDOT is adjusting two PM3 travel time reliability targets. The primary reason for adjusting to less stringent targets is that roadway construction scheduled for the interstate system across Pennsylvania in 2021 is anticipated to result in delays that will negatively impact travel time performance. The impact of construction work zones on the interstate system cannot be mitigated in 2021, but PennDOT will be developing appropriate mitigation strategies to address impacts in future years.

With no comments or discussion, *motion was made by Mr. Hall and seconded by Mr. Eich to select the option to plan and program projects that contribute toward the accomplishment of the statewide adjusted PM3 performance measure targets. The motion carried 17-0.*

**9. 2021-2024 Centre County Transportation Improvement Program (TIP)**

Mr. Zilla communicated that because of a significant increase on the estimated cost for construction of the Route 64/550 intersection safety project, PennDOT has been working to identify a source of funds that can be added to the TIP to address the cost increase. Mr. Ball, Assistant District 2-0 Engineer, explained that there is a need to stabilize soil under the proposed new section of road way due to the type of soil. In addition, because of the extent of the work that needs to be done to stabilize the soil, a community water line must be relocated.

Mr. Zilla explained that there are three options to obtain the funding needed for the Route 64/550 intersection safety project: uncommitted funds from a reserve line item on the Centre County TIP, new funds from the Highway Safety Improvement Program (HSIP) from the statewide TIP, or shifting funds from the construction phase of the Route 26 Jacksonville Road Betterment project. The schedule for the construction of the Route 26 Betterment is closely linked to the schedule for completing the I-80/Route 26 Local Access Interchange. Because the schedule for opening the Local Access Interchange has been pushed back, the schedule for completion of the Betterment project will also be pushed back. Thus, funds could be shifted from the construction phase of the Betterment project and replenished in the next 2023-2026 TIP without impacting the pre-construction phases of the project.

In response to a question from Mr. Johnson, Mr. Zurat explained that the cost for stabilizing the soil underneath the new section of road will cost about \$1 million, and the new community waterline will cost around \$500,000. He went on to say that based on the excavation limits that were in place at the start of the project, there was originally no effect on the waterline nearby; however, now that more intensive work is needed, the waterline will be affected, and Walker Township opted to upgrade its community waterline to accommodate a growing community. Mr. Johnson expressed his disappointment in the cost increase of this project and stated that the boring should have been done in preliminary phases of the project to capture an accurate cost.

*Motion was made by Mr. Decker and seconded by Mr. Shifflet to approve the amendments to the 2021-2024 Centre County TIP to provide additional funds to the Route 64/550 intersection project. The motion carried 17-0.*

**10. CCMPO Safety Subcommittee**

The Coordinating Committee received a report from Ms. Messner regarding the formation of a CCMPO Safety Subcommittee to help identify candidate roadway safety improvement projects to be considered for the

next 2023-2026 Transportation Improvement Program (TIP). Planning and preparation of the next TIP will begin this spring with an adoption date of June 2022. The new subcommittee would be comprised of a small number of members from the Technical Committee. At the November 17, 2020 Technical Committee meeting, the following members agreed to participate: Ron Seybert, Ferguson Township, Technical Committee Chair; George Harrigan, Harris Township; Joel Myers, Penns Valley Region; Dean Ball, PennDOT District 2-0; Frank Hampton, PennDOT Central Office, and Matt Smoker, FHWA

It is anticipated this committee will begin meeting in late February/early March and will continue to meet as needed through the timeframe when the new TIP is being developed in 2021.

*Motion was made by Mr. Johnson and seconded by Ms. Robb to form a safety subcommittee comprised of members of the Technical Committee. The motion carried 17-0.*

#### **11. U.S. Office of Management and Budget (OMB) – Federal Registrar Notice**

The Coordinating Committee received a report from Mr. Zilla regarding the Office of Management and Budget's (OMB) notice in the Federal Registrar seeking comment on recommended changes to OMB's standards for designating "metropolitan" and "micropolitan" statistical areas. The recommended changes would increase the population threshold for designating an area as "metropolitan" from 50,000 to 100,000 persons and reclassify areas between 50,000-99,999 persons as "micropolitan". The proposed change would reclassify nine areas in Pennsylvania from metropolitan to micropolitan status, including the State College Metropolitan Statistical Area (Centre County).

The OMB designations are used as the basis for collection and reporting of data by various agencies and are not used to designate metropolitan planning organizations (MPOs). MPO designations are based on Urbanized Areas delineated by the U.S. Census Bureau and by the U.S. Department of Transportation (USDOT) in federal transportation legislation and rulemaking. Currently, the population threshold used by the Census Bureau to designate an Urbanized Area is 50,000 persons.

Mr. Zilla communicated that MPO staff is coordinating with PennDOT and the other affected areas in PA to share information and determine whether the submission of comments to the OMB is relevant and appropriate. At this time, there is no evidence that the proposed OMB changes would directly impact the designation of the nine areas as MPOs. However, staff is concerned that later in 2021, the Census Bureau may redefine standards for designating Urbanized Areas and the USDOT may change the definition of MPOs to be more consistent with the new OMB standards, should they be enacted.

Public comments about the OMB's recommended change in standards must be submitted by March 19, 2021. Because it is unclear if the submission of comments would be necessary, staff is requesting that the Coordinating Committee authorize staff to submit comments by the March 19 deadline, if relevant and appropriate, and contingent upon review and approval by the CCMPO Chair. Staff is also seeking authorization to share any comments with Centre County's Congressional delegation.

In response to a question from Mr. Pipe, Mr. Zilla explained that the task force involved in this recommended change has been in place since 2018, and the new presidential administration has not addressed the report that the task force put out in 2020.

In response to questions from Mr. Eich, Mr. Zilla explained that the OMB's reason for this proposal had to do with the United States' population growth, and since the population has been redistributed over time, there has been a proliferation of areas right around that 50,000-population threshold. The OMB is proposing this change so that a true definition of urbanized area is reflected in the demographic data.

*Motion was made by Mr. Johnson and seconded by Ms. Strickland to authorize staff to prepare and submit comments about the OMB's proposed changes for updating the standards establishing metropolitan and micropolitan areas, if relevant and appropriate, contingent upon review and approval by the CCMPO Chair, and to share any comments with Centre County's Congressional delegation. Motion carried 17-0.*



**12. Member Reports**

Mr. Harden communicated that a citizen’s group in Harris Township has formed to discuss safety issues on Route 45. The group has been meeting regularly and is working with PennDOT District 2-0 to address bus stop safety in this corridor. There have been discussions about putting up signage and doing line paintings in this corridor to notify drivers that there is a bus stop nearby.

There were no other member reports.

**13. Announcements**

The next Technical Committee meeting is scheduled for 9:30 a.m. on Wednesday, April 14, 2021 viz the Zoom meeting platform. The next Coordinating Committee meeting is scheduled for 6:00 p.m. on Tuesday, April 27, 2021 via the Zoom meeting platform.

Mr. Bernier recognized Ms. Meek for her efforts in helping the Centre Region attain a Silver-level Bicycle Friendly Community designation by the League of American Bicyclists in December 2020. Mr. Bernier also recognized Ms. Meek for her coordination with Centre County municipalities on providing information and submitting comments regarding Act 106 – Personal Delivery Devices that Pennsylvania legislature adopted recently that took effect on January 31, 2021.

**14. Adjournment**

There being no further business, the February 23, 2021 CCMPO Coordinating Committee meeting was adjourned at 8:35 p.m.

Respectfully submitted,

Marcella Laird  
Recording Secretary

# APRIL 27, 2021 MEETING

## ITEM 4

### 2021-2024 CENTRE COUNTY TRANSPORTATION IMPROVEMENT PROGRAM (TIP)

#### TIP Revisions – Route 26/45 Intersection Safety Project

The 2021-2024 Centre County TIP was adopted by the CCMPO in June 2020 and took effect on October 1, 2020.

The TIP needs to be revised to address a slight increase in the estimated cost of the Route 26/45 intersection safety project.

Proposed Revision to 2021-2024 TIP			
Project	Original Funding	Change	Revised Funding
Route 26 Section N37 Route 26/45 Intersection Safety Improvement Construction Phase	\$5,318,613	+\$369,792	\$5,688,405

PennDOT District 2-0 is working to optimize the allocation of federal and state funds on the TIP in response to the impacts of the COVID pandemic. As a result, several funding shifts associated with the Route 26/45 project are being implemented, which will also address the cost increase. Overall, \$2,612,000 in federal funds are being added to the project, and \$2,242,766 in state funds are being shifted from the Route 26/45 project to other projects and a reserve line item on the TIP.

Although the total increase in cost is modest, the net increase in federal funds for this project exceeds \$1.5 million. Thus, formal action by the CCMPO to amend the TIP is being requested.

Staff will provide a brief report about the proposed revisions.

The Technical Committee recommended approval of the amendment to the TIP.

**The Coordinating Committee should receive the staff report and consider amending the TIP to include additional funds for the Route 26/45 project.**

Presented by: Tom Zilla, AICP, CRPA  
Dean Ball, P.E., PennDOT District 2-0

Action: Approve an amendment to the 2021-2024 Centre County TIP to provide additional funding for the Route 26/45 intersection safety project.

# APRIL 27, 2021 MEETING

## ITEM 5

### U.S. CENSUS BUREAU - FEDERAL REGISTER NOTICE

#### Proposed Criteria to Designate Urban Areas for the 2020 Census

On February 19, 2021, the U.S. Census Bureau (CB) published a notice in the Federal Register seeking comment about the proposed criteria that will be used to designate “urban areas” for the 2020 Census. Based on the past 2010 Census, there is one urbanized area and two urban areas designated in Centre County:

- State College Urbanized Area
- Bellefonte Urban Area
- Philipsburg Urban Area (extends into Clearfield County)

The most significant changes proposed for the 2020 designation include:

- Shift from population to housing density as the basis for designating census blocks that qualify as “urban”.
- Shift to only one “urban” area designation, and no longer designating “urban” and “urbanized” areas.
- Increase the minimum population threshold for designating an “urban” area from 2,500 persons to 10,000 persons.
- Add a minimum housing unit threshold of 4,000 housing units for designating an “urban” area (***an area may be designated as “urban” based on the minimum housing unit or the minimum population***).

Currently, the total population in an “urbanized” area is used by the U.S. Department of Transportation to designate metropolitan planning organizations (MPOs), based on a minimum population threshold of 50,000 persons. Urban and urbanized area designations may also be used for collection and reporting of data by various agencies, and for other purposes ranging from program eligibility to roadway design standards.

The Centre Regional Planning Agency, Centre County Planning and Community Development Office, and Centre County GIS Office have been reviewing the proposed changes to assess potential impacts to the three areas currently designated in Centre County.

The deadline to submit comments to the Census Bureau is May 20, 2021. MPO staff is requesting authorization from the Coordinating Committee to submit comments, **if relevant and appropriate**, and contingent upon review and approval by the CCMPO Chair. Currently, staff believes that comments will be focused on technical elements and not on policy items.

The Technical Committee recommended that the Coordinating Committee authorize staff to submit comments.

**The Coordinating Committee should receive a staff report and consider providing authorization to staff to submit comments.**

Presented by: Tom Zilla, AICP, CRPA

Action: Authorize staff to prepare and submit comments to the U.S. Census Bureau about proposed changes for designating urban areas, if relevant and appropriate, contingent upon review and approval by the CCMPO Chair, and to share any comments with Centre County’s Congressional delegation.

# APRIL 27, 2021 MEETING

## ITEM 6.a.

### TRANSPORTATION FUNDING INITIATIVES

#### Federal Discretionary Funding (Member Designated Projects) Requests

In late February, U.S. House of Representatives Committee leaders announced that an opportunity was being provided for House members to submit candidate projects for congressionally directed spending in the upcoming reauthorization of the federal transportation legislation (FAST Act).

MPO staff worked with PennDOT and congressional staff from Centre County's two House members to identify and submit three candidate projects for discretionary funding in the transportation reauthorization legislation.

PennDOT MPMS#	State Route	Section	Name	Total Cost of Construction Phase	Requested Discretionary Funding for Construction Phase	Congressional District
112588	26	147	Jacksonville Rd. Betterment	\$6,000,000	\$5,000,000	15 <sup>th</sup> Rep. Thompson
88217	4005	A02	I-80 Exit 147 Bridge over I-80 at Snow Shoe Interchange	\$7,100,000	\$5,000,000	15 <sup>th</sup> Rep. Thompson
101960	3014	153	Atherton Street Drainage/Repaving	\$17,500,000	\$5,500,000	12 <sup>th</sup> Rep. Keller

The three projects met federal eligibility criteria and PennDOT guidelines, in particular: a) being on the MPO LRTP and TIP; and b) being able to advance to a bid letting within an approximate 18-month timeframe. The projects also have strong support from PennDOT because of benefits associated with meeting federal performance measure targets for the Interstate and National Highway Systems. PennDOT provided letters of support/commitment that were required in the submission package to confirm the ability of the sponsor to advance the projects. (The CCMPO is the sponsor for submission of the requests).

Because the submission deadlines were extremely short, MPO staff discussed these candidates with the MPO Chair and Vice-Chair and received their concurrence to submit the projects.

Staff will provide a brief report.

**The Coordinating Committee should receive the staff report and consider endorsing the submission of the three candidate projects.**

Presented by: Tom Zilla, AICP, CRPA

Action: Endorse the submission of three candidate projects to U.S. Representatives Thompson and Keller to be considered for discretionary funding in the next federal transportation authorization legislation.

# APRIL 27, 2021 MEETING

## ITEM 6.b.

### TRANSPORTATION FUNDING INITIATIVES

#### **PennDOT Pathways Initiative**

In November 2020, PennDOT announced the start of the PennDOT Pathways Program, a new initiative to examine options for addressing the transportation funding shortfall in Pennsylvania. The announcement noted that PennDOT faces an \$8.1 billion gap in annual highway and bridge funding needed to keep the network in a state of good repair.

In February, PennDOT Deputy Secretary for Planning Larry Shifflet provided presentations to the CCMPO Committees about the Pathways initiative, which includes completion of a Planning and Environmental Linkages (PEL) Study of potential funding options. The initial results from the PEL Study are tentatively scheduled to be published for public comment in late April or May 2021.

Three documents are provided as background for this agenda item:

- Graphic illustrating potential funding solutions
- Comments from the Technical Committee's April 14 discussion of potential options
- Past CCMPO policy positions about transportation funding

Staff will provide a brief overview of the potential solutions.

**The Coordinating Committee should initiate a discussion of the potential funding options.**

The discussion is intended to be the starting point for preparation of input from the CCMPO during the public comment period for the PEL Study. Depending on the timing of the public comment period, the Coordinating Committee may need to schedule a special meeting in May to review the study and finalize comments.

Presented by: Tom Zilla, AICP, CRPA

Action: Discuss potential options for increasing state funding for transportation.

# Potential Funding Solutions



## Bridge Tolling

Tolling is a proven way to fund costly infrastructure projects like bridges. In the United States there are 137 bridge tolls, including three in our backyard over the Delaware river. In fact, the Delaware River Joint Toll Bridge Commission temporarily converted the Scudder Falls Bridge over the Delaware River into a toll bridge only in 2019 in order to fund its replacement.



## Managed Lanes

Managed Lanes are additional lanes on a highway where the traffic is managed for faster travel. With managed lanes, traffic can be regulated by charging a toll, or by encouraging carpooling. It offers a choice to drivers — to pay a fee, carpool, or use the regular lanes.



## Congestion Pricing

Congestion pricing is another form of tolling where toll rates vary based on the congestion on the roadway — encouraging users to carpool or use alternative routes when traffic gets too heavy — creating a reliable speed and trip.



## Corridor Tolling

Corridor tolling is similar to what we currently have on the Pennsylvania Turnpike. Corridor tolling means tolling interstates and expressways based on the distance traveled along that road.



## Road User Charges

These charges are a little different from tolls in that they are generally tied to GPS technologies to calculate the number of miles you drive. Essentially, drivers would be charged a small fee for each mile they drive during the year.



## Fee & Tax Increases

This would include increasing vehicle-related fees and/or increasing various taxes, with the exception of the gas tax.

Some of these potential funding strategies might work better in certain scenarios and locations than others. It's important that as we study funding options, we consider how different strategies could work together as both near- and long-term solutions.

## What Have We Done So Far?



We've worked hard to make the most of our available funding and have found some ways to secure additional funding. For example, with the help of Act 44 and Act 89, we were able to generate revenue from the Pennsylvania Turnpike and gas taxes, allowing us to complete nearly 4,000 projects worth more than \$10 billion since its passage in 2013. We have more than 500 projects underway worth more than \$4.5 billion, and roughly 1,700 projects on our four or 12-year plans. While Act 89 was a significant achievement, it did not meet the needs identified at the time and those needs have grown over time.

See active and planned construction projects at [www.projects.penndot.gov](http://www.projects.penndot.gov).

# PennDOT Pathways Program

To support PennDOT Pathways, an alternative funding Planning and Environmental Linkages (PEL) study is underway to identify near- and long-term funding solutions and establish a methodology for their evaluation. One of the early findings of the PEL study is that bridge tolling of major bridges in need of replacement or rehabilitation could be a viable near-term solution. To advance this funding alternative, PennDOT is simultaneously pursuing the first initiative of the PennDOT Pathways Program: The Major Bridge P3 Initiative.

## PennDOT Pathways

A long-term program to analyze and implement new future-focused sources of funding for our transportation system that could better serve our communities and all Pennsylvanians for the next generation.

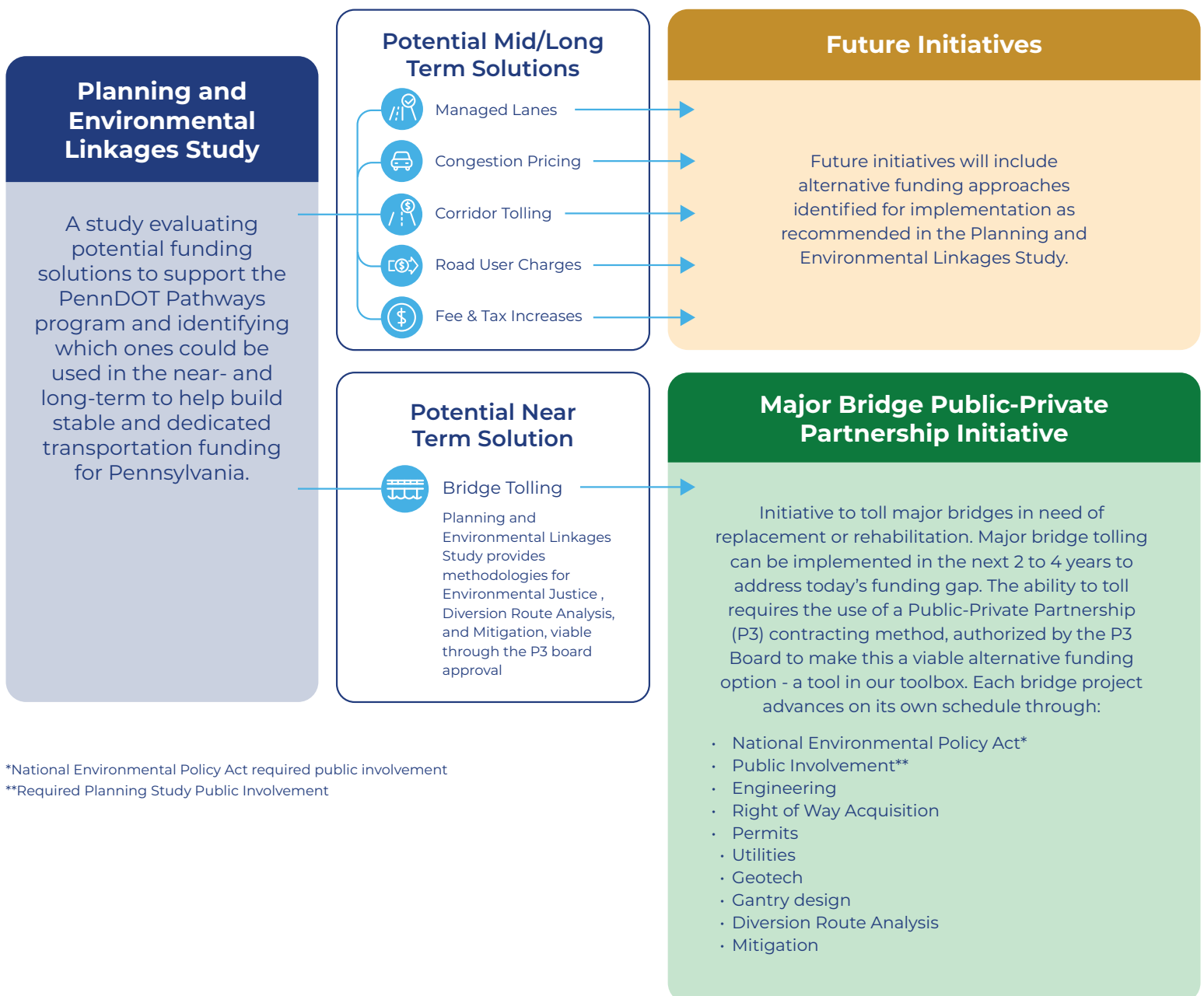

\*National Environmental Policy Act required public involvement

\*\*Required Planning Study Public Involvement

## **CCMPO Technical Committee**

**April 14, 2021 Meeting**

### **Comments about Transportation Funding Solutions**

*(The following list is a compilation of comments, and does not represent a consensus or vote by a majority of Committee members regarding specific positions).*

#### Tolling

- Bridge tolling impacts too specific of a localized area...revenue needs must be spread over a larger area.
- Drivers will take local roads and parallel routes to avoid tolls.
- Will tolling or Vehicle Miles Traveled (VMT) tax include all users, and not just PA residents?
- If considering corridor tolling of interstate highways, must toll all interstates to avoid localized economic impacts and traffic diversion to local roads.
- Support tolling of managed lanes and/or other surcharges that are based on a user's choice to use the facility and incur the cost.

#### Road User Charges

- Expenses for maintaining roads and bridges need to be shared by electric vehicles (EVs).
- Must consider ways of taxing out of state users.
- One option is to increase gas tax, but collect and monitor VMT data to allow refunding of excess amount of gas tax. Allows gas tax to be charged to out of state users, and allows EVs and hybrids to pay a fair share.
- If state gas tax continues to increase, residents in areas along the PA border will travel to adjacent states to purchase gas.
- A VMT tax + a variable registration fee indexed to different classes of vehicles (heavier pays more) shifts the focus of revenue generation away from fuel or means of propulsion.
- How can a VMT tax be collected on out of state users?

#### Fees/Taxes

- Prefer fees and taxes applied to the general population.
- In many other states, local officials are given the ability to raise revenue to support transit.
- Need more authority for revenue generation to be given to local officials so they can be creative in supporting transportation needs.
- Charge fee by weight of vehicle (assume higher weight vehicles cause more wear and tear, so charge higher fee).



## Fees/Taxes (Continued)

- Charge additional tax on electricity from charging stations.
- Apply user charges for EV charging stations so that out of state users contribute.
- There is no political will in the PA State Legislature to tax EVs.
- Charge fees at PA border locations so that out of state drivers pay a share...there are a lot of out of state drivers traveling to the State College area.

## General

- Don't want unintended consequences of different option, so must ask if the status quo is good enough.
- Must educate residents about costs of maintaining transportation system.
- Size of PA's state-owned road system creates great need for revenue.
- Less traveled state-owned "legacy" roads should be maintained by local governments, and local officials should be given freedom to generate revenue to support maintenance of the transportation system.
- A "one-size" solution doesn't fit all areas. For example, rural areas can't make up loss of state funding for transit.
- Need multiple layers of solutions and redundancy among layers.
- In PA, Liquid Fuels tax and revenue is critical to municipalities.
- In rural settings, municipalities can't generate enough revenue to maintain roadways.
- Hydrogen fuel cell development may overcome electric as a means of propulsion.
- State government can't burden only PA residents with the responsibility for funding the system.
- PA's location in the northeast United States brings many out of state users through the state's transportation system.
- Technology in all aspects of transportation is constantly changing, and the industry must adapt quickly.

## **Summary of Recent CCMPO Policy Positions about Transportation Funding**

### January 2008 – Proposed Tolling of Interstate 80

By a 13-1 vote, with 3 abstentions:

The Coordinating Committee indicated that it supported the intent of Pennsylvania Act 44 to provide a dedicated, predictable, and growing source of revenue for highway, bridge and public transportation improvements, but was opposed to the tolling of 1-80 as a method for generating revenue. The motion urged then-Governor Rendell and the State Legislature to consider other revenue options, such as the methods proposed by the Transportation Funding and Reform Commission (TFRC) in 2006, and to select an alternative to placing tolls on 1-80.

### November 2009 – Proposed Tolling of Interstate 80

By a 14-1 vote, with 2 abstentions:

The Coordinating Committee indicated its strong opposition to the tolling of 1-80 for reasons associated with negative economic impact to businesses, traffic diversions to other roadways, and the need to create an additional bureaucracy for toll collection. Details are included in the attached correspondence from the CCMPO to the U.S. Department of Transportation.

### June 2010 – State Transportation Funding

By 14-0 votes, the Coordinating Committee supported:

- Action to adjust the motor fuel tax to compensate for the rate of inflation over the past 10 years and index it for future inflation.
- Action to increase the level of funding committed to the Pennsylvania Infrastructure Bank.

In other votes:

- 13 of 14 members did not support shifting from a motor fuels tax to a vehicle miles traveled (VMT) tax/fee, because of equity questions and the cost of developing a new infrastructure to assess and collect revenue.
- The Coordinating Committee indicated that options for roadway tolling should continue to be studied, but did not take a position in support of, or opposed to, tolling methods.

March 2012 – Federal *Moving Ahead for Progress in the 21<sup>st</sup> Century Act (MAP-21)*

Unanimously, the Coordinating Committee supported:

- Preservation of all existing small MPOs in the transportation planning process.
- An overall funding level at or above the amount proposed for *MAP-21*, acknowledging that reducing funding will clearly have a negative impact on state and local officials' ability to advance transportation improvements.

February 2015 – Reauthorization of *MAP-21*

Unanimously, the Coordinating Committee supported the attached position statement.

There was little support for including a vehicle miles traveled (VMT) tax as a funding option based on uncertainties surrounding whether an increase in the gas tax would occur in conjunction with a VMT tax, disproportionately impacting rural areas.

## APRIL 27, 2021 MEETING

### ITEM 7.a.

#### PERFORMANCE BASED PLANNING AND PROGRAMMING

##### **CATA and Centre County Office of Transportation Transit Asset Management (TAM) Performance Measure Targets**

Federal rulemaking required all public transit operators to develop a Transit Asset Management (TAM) Plan and performance targets by October 1, 2018. The TAM Plan and performance targets must be shared with states and MPOs, but there is no requirement for states and MPOs to approve the TAM Plans and their associated performance targets.

Both CATA and the Centre County Office of Transportation Services (CCOT) are subject to this federal rule. CATA maintains an individual TAM Plan and performance targets, and the CCOT is covered by a statewide TAM Group Plan and performance targets, prepared by PennDOT on behalf of transit operators in Pennsylvania. Both individual and statewide TAM Plans specify a reporting process to assess progress in meeting the targets.

Federal rulemaking also requires states, MPOs, and public transit operators to prepare specific written provisions for cooperatively developing and sharing information related to transportation performance data, including the selection of targets and documenting progress toward meeting TAM Plan targets. Thus, agreements are in place between CATA, Centre County, PennDOT, and the CCMPO to document the cooperative development and sharing of public transportation performance data.

The CCMPO is required to adopt a set of TAM performance targets for use in planning and programming activities. There are no funding incentives for meeting or exceeding targets, and no penalties for failure to meet targets. Rather, adoption of these targets is intended to fulfill an important administrative requirement, and to help guide planning and programming decisions with respect to asset management.

MPO staff will provide a presentation about the TAM Plans, performance targets, and data sharing, and how these might translate into MPO asset management targets for adoption in June 2021.

**The Coordinating Committee should receive the report and provide any questions to MPO staff.**

**No action is required at this meeting. This item will be presented to the MPO Committees again in June, when action will be required by the Coordinating Committee to adopt TAM performance targets.**

Presented by: Greg Kausch, CRPA

No action required.

## **APRIL 27, 2021 MEETING**

### **ITEM 7.b.**

#### **PERFORMANCE BASED PLANNING AND PROGRAMMING**

##### **CATA Public Transportation Safety Performance Measure Targets**

Federal rulemaking required all public transit operators who are either direct recipients or subrecipients of federal Urbanized Area Formula (Section 5307) funding to develop a Public Transportation Agency Safety Plan (PTASP) and performance targets by December 31, 2020. The PTASP and performance targets must be shared with the Federal Transit Administration (FTA) and MPOs, and while the FTA has enforcement authority with respect to individual public transportation providers, there is no requirement for MPOs to approve the PTASP and its associated performance targets.

The CATA Board of Directors adopted a PTASP and performance targets on December 14, 2020. Prior to adoption, CATA staff submitted its PTASP and performance targets to FTA for voluntary review and addressed all input stemming from the FTA review. CATA is now deemed to be in full compliance with all PTASP requirements.

Because it is not a direct recipient or a subrecipient of federal Section 5307 funds, the Centre County Office of Transportation Services (CCOT) is not subject to PTASP requirements.

The CCMPO is required to adopt a set of safety performance targets for use in planning and programming activities. These targets must be adopted within 180 days of the December 31, 2020 deadline. There are no funding incentives for meeting or exceeding targets, and no penalties for failure to meet targets. Rather, adoption of these targets is intended to fulfill an important administrative requirement, and to help guide planning and programming decisions with respect to public transportation safety.

MPO staff will provide a presentation about CATA's PTASP, performance targets, and data sharing, and how these might translate into MPO public transportation safety targets for adoption in June 2021.

**The Coordinating Committee should receive the report and provide any questions to MPO staff.**

**No action is required at this meeting. This item will be presented to the MPO Committees again in June, when action will be required by the Coordinating Committee to adopt public transportation safety performance targets.**

Presented by: Greg Kausch, CRPA

No action required.

# **APRIL 27, 2021 MEETING**

## **ITEM 8**

### **PennDOT PROJECT UPDATE**

#### **Status Report from PennDOT District 2-0 about Highway and Bridge Projects**

PennDOT District 2-0 will provide an update about the status of highway and bridge projects in Centre County.

PennDOT's One Map website at <https://www.dot7.state.pa.us/OneMap> provides information about active and future projects on the Transportation Improvement Program (TIP) and Twelve Year Transportation Program (TYP).

**The Coordinating Committee should receive the presentation.**

Presented by: Dean Ball, P.E., PennDOT District 2-0

No action required.

# APRIL 27, 2021 MEETING

## ITEM 9

### STATE COLLEGE AREA CONNECTOR (SCAC) PROJECT

#### Status Report

A status report about the SCAC Planning and Environment Linkages (PEL) Study is being included on all CCMPO meeting agendas to keep committee members informed about the progress and status of work.

The PEL Study is scheduled to be completed in spring 2022. The study will identify transportation improvements to be advanced for environmental consideration and further design in the next step, the Preliminary Engineering (PE) phase. The PE phase will include a more detailed analysis of the study area's socio-economic, natural, and cultural resources; the development and evaluation of transportation alternatives; the identification of a preferred alternative; and obtaining environmental clearance for the preferred alternative.

The first public meeting for the PEL Study was held virtually from October 28 through November 4, 2020 and included information about the transportation purpose and needs in the study area. The SCAC Purpose and Need document is available on the project website (see web address below).

PennDOT's consultant team is currently developing a range of alternatives to address the purpose and need, and the alternatives will be displayed during the next public meeting scheduled for late August 2021.

**The Coordinating Committee should receive the status report and provide comments.**

Presented by: Dean Ball, P.E., PennDOT District 2-0

Action: Comments to PennDOT and SCAC consultant team.

\*\*\*\*\*

*SCAC website: [www.PennDOT.gov/SCAC](http://www.PennDOT.gov/SCAC)*

# APRIL 27, 2021 MEETING

## ITEM 10

### CCMPO SAFETY SUBCOMMITTEE

#### Status Report about Safety Subcommittee Activities

The MPO staff and PennDOT are working to identify candidate roadway safety improvement projects that can be considered for the next 2023-2026 TIP. Development of the 2023-2026 TIP will begin in late spring 2021.

Financial guidance and project priorities for the TIP will be discussed by the CCMPO in September. A Preliminary Draft TIP will be prepared for review in November 2021, and a final Draft TIP will be completed in December. The new TIP will be adopted in June 2022.

To facilitate the identification of candidate safety projects, in February the Coordinating Committee approved the formation of a Safety Subcommittee comprised of a small number of members from the Technical Committee.

The Subcommittee held its kick-off meeting on March 8, 2021 and received presentations regarding the importance of safety from the Federal Highway Administration (FHWA) perspective (Matt Smoker, FHWA PA Division Office) and the PennDOT Central Office perspective (Gavin Gray, PennDOT Bureau of Operations and Maintenance). Intersections of concern in Centre County that were identified by crash data were also reviewed.

The Subcommittee held its second meeting on April 6, 2021. Dean Ball from PennDOT District 2-0 reviewed anticipated safety improvements that have been, or will be, completed as part of the Atherton Street Drainage/Repaving project in Sections 152 and 153. Multiple intersections of concern were identified in the Atherton Street corridor and understanding the improvements will help inform the Subcommittee on safety improvement options. Roadway segments of concern that were identified by crash data were also reviewed.

MPO staff will provide a brief report about the Subcommittee's discussions.

**The Coordinating Committee should receive the staff report.**

Presented by: Anne Messner, AICP, CCPCDO

No action required.



# APRIL 27, 2021 MEETING

## ITEM 12

### ANNOUNCEMENTS

#### 1. Future Meeting Dates

- a. Technical Committee: Wednesday, June 9, 2021, 9:30 a.m.  
*Anticipated virtual meeting via Zoom platform*

- ⇒ Centre Region Climate Action and Adaptation Plan
- ⇒ State transportation funding
- ⇒ Transit safety performance measure targets
- ⇒ Transit asset management performance targets
- ⇒ Unified Planning Work Program
- ⇒ Safety project development
- ⇒ State College Area Connector

- b. Coordinating Committee: Tuesday, June 22, 2021, 6:00 p.m.  
*Anticipated virtual meeting via Zoom platform*

- ⇒ Centre Region Climate Action and Adaptation Plan
- ⇒ State transportation funding
- ⇒ Transit safety performance measure targets
- ⇒ Transit asset management performance targets
- ⇒ Unified Planning Work Program
- ⇒ Safety project development
- ⇒ State College Area Connector

2. The Centre County Board of Commissioners has appointed David W. Lomison, Director of the Centre County Office of Transportation, to be the County's second representative to the CCMPO Technical Committee. MPO and CATA staff have worked with Dave for many years as part of the planning and delivery of public transit service in the County.

In addition, Philipsburg Borough and Rush Township have appointed Michelle Merrow from Alder Run Engineering, the Township's consulting engineer, to represent the Moshannon Valley Planning Region on the CCMPO Technical Committee. On behalf of members of the MPO Committees and staff, welcome aboard Dave and Michelle!

3. The CCMPO's *Procedures for Transportation Improvement Program (TIP) Revisions* allow project sponsors (typically PennDOT and CATA) to make administrative modifications that change funding on the TIP without formal approval by the Coordinating Committee. The *Procedures* specify that the administrative modifications be reported to the CCMPO for information purposes. Attached are administrative modifications completed since the February CCMPO meetings.

4. The federal Transportation Alternatives (TA) Set-Aside Program provides funding for projects and activities defined as transportation alternatives, including on- and off-road pedestrian and bicycle facilities, infrastructure projects for improving non-driver access to public transportation and enhanced mobility, community improvement activities, and environmental mitigation, trails that serve a transportation purpose, and safe routes to school projects.

PennDOT administers the TA Program, and is currently updating the TA Guidance document and anticipates opening a funding application round in July 2021. For more info visit the PennDOT TAP <https://www.penndot.gov/ProjectAndPrograms/Planning/Pages/Transportation%20Alternatives%20Set-Aside%20-%20Surface%20Trans.%20Block%20Grant%20Program.aspx>. MPO staff will provide information to municipalities and interested parties when it becomes available.

5. On April 16, 2021, Governor Tom Wolf announced the award of funds from PennDOT’s Multimodal Transportation Fund program for projects across Pennsylvania, including one project in Centre County:

Project	Municipality	Allocation
Sponsor: Toftrees Development LLC  Construct Masters Boulevard/Waddle Road Extension, including excavation, paving, sidewalks, traffic signal and stormwater management.	Patton Twp.	\$2,440,000

Municipal projects sponsored and submitted by Milesburg Borough and Boggs Township were not approved for funding.

6. Following the adoption of the CCMPO’s Long Range Transportation Plan (LRTP) 2050 in September 2020, staff has been working to develop a “dashboard” to track progress on work tasks identified in the LRTP’s Action Plan. The dashboard is intended to show the anticipated work to be completed prior to and during the mid-term update of the LRTP. The dashboard will be reviewed periodically to determine progress and modifications needed. The dashboard is attached.
7. May is National Bike Month, promoted by the League of American Bicyclists and celebrated in communities from coast to coast. Established in 1956, National Bike Month is a chance to showcase the many benefits of bicycling and encourage more folks to give biking a try. MPO staff worked with local bike organizations and interested parties to program education and encouragement activities throughout the month of May. Virtual, solo, and household events have been designed to allow for social distancing. Additional information about Bike Month activities in Centre County can be found at [www.crcog.net/bikes](http://www.crcog.net/bikes).

Also, please see the newest episode of C-NET's "Around the County" at <https://videoplayer.telvue.com/player/GNduNoua2rBThhw6N4PRP9OCSPf6B2ru/playlists/4804/media/634493?autostart=false&showtabssearch=true&fullscreen=false&jwsource=cl> featuring CRPA Senior Transportation Planner Trish Meek.

8. The Pennsylvania Department of Health (DOH), Division of Nutrition and Physical Activity, in collaboration with the Pennsylvania Downtown Center, continues its mission to increase opportunities for physical activity utilizing the built environment through the WalkWorks program. The WalkWorks program offers grants to public agencies, such as municipalities and planning commissions, for the development of active transportation plans (ATPs) and related policies.
- WalkWorks has announced its fifth round of funding assistance to advance policy development related to active transportation. Grants will be offered to a limited number of municipalities and other governmental bodies to assist with the development of ATPs, Complete Streets policies and/or Vision Zero policies. These plans and policies are essential to efforts to establish activity-friendly routes that connect people to everyday destinations, thereby expanding opportunities for physical activity. Eligible applicants include municipalities, Metropolitan and Rural Planning Organizations, and other governmental agencies with the capacity to accomplish proposed projects. For information about WalkWorks, including the location of partners and walking routes, as well as previously funded municipalities and agencies, please visit the PA WalkWorks website: <https://www.health.pa.gov/topics/programs/WalkWorks/Pages/WalkWorks.aspx>

9. The Centre Region Council of Governments is working on the preparation of a Climate Action and Adaptation Plan (CAAP). The CAAP will build upon the compilation of a recently completed Greenhouse Gas Inventory and will guide sustainability efforts in the Centre Region.  
The CAAP and associated sustainability efforts are referenced in the CCMPO’s LRTP 2050. In June, CRPA Sustainability Planner Pam Adams will provide presentations to the Technical and Coordinating Committees about the CAAP and sustainability planning efforts that are underway in the Centre Region. Similar efforts are underway in Bellefonte Borough. These efforts will help build a framework for the MPO to support sustainability planning efforts in other areas of Centre County.
10. The CCMPO’s FY 2020-2022 Unified Planning Work Program (UPWP) was adopted in January 2020 and took effect on July 1, 2020. The next FY 2022-2024 UPWP will be prepared this year, with adoption tentatively scheduled for late 2021 or early 2022. The new FY 2022-2024 UPWP will go into effect on July 2, 2022. MPO staff will be seeking input from Committee members in June about possible work tasks that may be included in the new UPWP.  
In preparation for the June discussions, Committee members are encouraged to browse through the current UPWP and identify key tasks that should be carried forward to the new UPWP, as well as potential new tasks. The UPWP may be found on the MPO website at [https://www.crcog.net/index.asp?Type=B\\_BASIC&SEC={9E98C1F3-7FB2-4514-89C9-5FEB5A41AD13}](https://www.crcog.net/index.asp?Type=B_BASIC&SEC={9E98C1F3-7FB2-4514-89C9-5FEB5A41AD13}).
11. For information about PennDOT’s Local Technical Assistance Program (LTAP) training courses, as sponsored by the SEDA-COG MPO, visit <http://seda-cog.org/departments/transportation/local-technical-assistance-program/>
12. For information about the *PennDOT Connects* initiative, visit the *Connects* support hub at <https://connect.psats.org/home>. **Information about technical assistance that is available to municipalities is posted on the *Connects* support hub.**
13. For information about the “Drive Forward” coalition formed by the Chamber of Business and Industry of Centre County (CBICC) with the support of the CCMPO, visit the Drive Forward website at [www.driveforwardcc.com](http://www.driveforwardcc.com).

14. CCMPO staff contact information:

Centre Regional Planning Agency	Telephone:	814-231-3050
2643 Gateway Drive	Fax:	814-231-3083
State College, PA 16801		

Jim May, Director	<a href="mailto:jmay@crcog.net">jmay@crcog.net</a>
Tom Zilla, Principal Transportation Planner	<a href="mailto:tzilla@crcog.net">tzilla@crcog.net</a>
Trish Meek, Senior Transportation Planner	<a href="mailto:tmeek@crcog.net">tmeek@crcog.net</a>
Greg Kausch, Senior Transportation Planner	<a href="mailto:gkausch@crcog.net">gkausch@crcog.net</a>
Pam Adams, Sustainability Planner	<a href="mailto:padams@crcog.net">padams@crcog.net</a>
Marcella Laird, Office Manager	<a href="mailto:mlaird@crcog.net">mlaird@crcog.net</a>

Centre County Plng & Community Dev. Office	Telephone:	814-355-6791
420 Holmes Street – Willowbank Office Building	Fax:	814-355-8661
Bellefonte, PA 16823		

Ray Stolinis, Director	<a href="mailto:rjstolinis@centrecountypa.gov">rjstolinis@centrecountypa.gov</a>
Elizabeth Lose, Assistant Director	<a href="mailto:eatuck@centrecountypa.gov">eatuck@centrecountypa.gov</a>
Anne Messner, Senior Transportation Planner	<a href="mailto:ammessner@centrecountypa.gov">ammessner@centrecountypa.gov</a>

On the web at [www.ccmppo.net](http://www.ccmppo.net) . Like and share the CCMPO’s Facebook page at <https://www.facebook.com/centrecountympo/> for meeting announcements, project updates, PennDOT’s Local Technical Assistance Program (LTAP) announcements, District 2-0 press releases, and relevant items from PennDOT’s Facebook page.

Centre County MPO  
2021 Highway and Bridge TIP  
FISCAL CONSTRAINT TABLE  
Actions Completed  
for District 2-0

\* Positive number denotes a deposit/Negative in parentheses denotes a debit

Administrative Actions			Fund Type	FFY 2021			FFY 2022			FFY 2023			FFY 2024			Outer Years			Grand Sum	Remarks			
Project Title	MPMS	Phase	Amts.	Fed. Sta.	Fed. (\$)	State (\$)	Loc/Oth (\$)	State (\$)	Loc/Oth (\$)	Fed. (\$)	State (\$)	Loc/Oth (\$)	Fed. (\$)	State (\$)	Loc/Oth (\$)	Fed. (\$)	State (\$)	Loc/Oth (\$)					
1	Poor Bridge / Betterment Line Item Reserve Line Item Centre County	84343	CON	Before STP		294,600												503,120		797,720	Influx of de-obligation funds.		
				Adjust STP		231,033															231,033		
				After STP		525,633	0	0	0	0	0	0	0	0	0	0	0	503,120	0	0	1,028,753		
2	Poor Bridge / Betterment Line Item Reserve Line Item Centre County	84343	CON	Before BOF		58,681															58,681	Influx of de-obligation funds.	
				Adjust BOF		58,681																58,681	
				After BOF		109,361	0	0	0	0	0	0	0	0	0	0	0	0	0	0	109,361		
3	Puddintown-Orchard Bike Bicycle/Pedestrian TAP project Centre County	104274	PE	Before TAP		0															0	Adding Preliminary Engineering (PE) phase back to TIP with a minor increase. Note: Construction phase was obligated on previous TIP.	
				Adjust TAP		5,000																5,000	
				After TAP		5,000	0	0	0	0	0	0	0	0	0	0	0	0	0	0	5,000		
4	SR 26 / 45 Shigletown Intersection SR 26, Section N 37 Centre County	76136	CON	Before 185								900,000									900,000	Freed up State 185 as preparatory for incoming NHPP in subsequent action. See amendment sheet.	
				Adjust 185								(900,000)									(900,000)		
				After 185		0	0	0	0	0	0	0	0	0	0	0	0	0	0	0	0		
5	SR 1022 Marsh Creek Br. SR 1022, Section A14 Centre County	91418	CON	Before BOF 185			544,000			668,000	476,497		668,000			668,000					3,024,497	Swap out federal BOF for State bridge funds, otherwise no change in overall cost.	
				Adjust BOF 185			(544,000)				544,000											0	
				After BOF 185		0	0	0	0	668,000	1,020,497	0	668,000	0	0	668,000	0	0	0	0	3,024,497		
6	Poor Bridge / Betterment Line Item Reserve Line Item Centre County	84343	CON	Before BOF 185		109,361		544,000				356,000		212,431							321,792	Reserve Line Item.	
				Adjust BOF 185		109,361		544,000				356,000		212,431							900,000		
				After BOF 185		218,722	0	1,088,000	0	0	356,000	0	212,431	0	0	212,431	0	0	0	0	1,221,792		
				Before		0	0	0	0	0	0	0	0	0	0	0	0	0	0	0	0	0	
				Adjust		0	0	0	0	0	0	0	0	0	0	0	0	0	0	0	0	0	
				After		0	0	0	0	0	0	0	0	0	0	0	0	0	0	0	0	0	
				Before FFY Totals		454,641	0	544,000	0	668,000	1,376,497	0	668,000	212,431	0	1,171,120	0	0	0	0	5,994,689	Fiscal ok as \$289,714 de-obs and small amount	
				Adjustment FFY Totals		294,714	0	0	0	0	0	0	0	0	0	0	0	0	0	0	294,714	\$5k of TAP.	
				After FFY Totals		749,355	0	544,000	0	668,000	1,376,497	0	668,000	212,431	0	1,171,120	0	0	0	0	5,389,403		

Agenda Item 11.6 L RTP Dashboard

Action	Jan-21	Feb-21	Mar-21	Apr-21	May-21	Jun-21	Jul-21	Aug-21	Sep-21	Oct-21	Nov-21	Dec-21	Jan-21	Feb-21	Mar-21	Apr-21	May-21	Jun-21	
Stakeholder Actions																			
Analyze stakeholder meeting inputs																			
Continue Stakeholder meetings	TBD																		
Develop safety education for all users																			
Transit preservation operations and level of service																			
Encourage Complete Streets Adoption																			

= Prepare update to MPO

Action	Jan-21	Feb-21	Mar-21	Apr-21	May-21	Jun-21	Jul-21	Aug-21	Sep-21	Oct-21	Nov-21	Dec-21	Jan-21	Feb-21	Mar-21	Apr-21	May-21	Jun-21	
Performance Measure Actions																			
Continue to update PM data																			
Work to reduce the number of poor condition bridges																			
Work to reduce the number of highway miles in poor condition																			
Work to reduce crashes, serious injuries and ped and bikes																			
Maintain National Highway system (NHS) in good condition																			
Maintain transit vehicles & other assets in a state of good repair																			

= Prepare update to MPO

Action	Jan-21	Feb-21	Mar-21	Apr-21	May-21	Jun-21	Jul-21	Aug-21	Sep-21	Oct-21	Nov-21	Dec-21	Jan-21	Feb-21	Mar-21	Apr-21	May-21	Jun-21
<b>Social Justice Actions</b>				[Dark Blue Bar]														
Expand equity analysis beyond the Environmental Justice (EJ) requirements for minority and low-income populations to identify barriers to transportation access for other populations																		

= Prepare update to MPO

Action	Jan-21	Feb-21	Mar-21	Apr-21	May-21	Jun-21	Jul-21	Aug-21	Sep-21	Oct-21	Nov-21	Dec-21	Jan-21	Feb-21	Mar-21	Apr-21	May-21	Jun-21
<b>Resiliency Action</b>	[Dark Blue Bar]																	
Educate users on resiliency planning efforts																		
Protect and enhance the environment, promote energy conservation and improve quality of life																		
Prioritize the climate vulnerabilities in our transportation systems																		
Integrate with other regional plans																		

= Prepare update to MPO

- Color key
- Brainstorming
  - Working the data
  - Final development



## **Manager's Report May 3, 2021**

1. Staff submitted an application to the Happy Valley Adventure Bureau Tourism Grant Program for the "Route 45 Getaways" event discussed at the April 19<sup>th</sup> Regular Meeting. The Board committed local match in an amount not to exceed \$4,500.00 to support the event. I will notify the Board when an announcement is made.
2. Provided with my report is a letter from Dan Lambe, President of the Arbor Day Foundation, congratulating the Township for earning recognition as a 2020 Tree City USA community.
3. Lance King has provided me his resignation letter as Township Arborist effective May 7, 2021. With Lance's guidance, we achieved our first Tree City USA designation and established a Tree Commission to guide our management of public and private trees. We wish him luck on his next endeavor.
4. The Happy Valley Adventure Bureau and Chamber of Business and Industry of Centre County held an Agritourism Committee meeting on April 21<sup>st</sup>. I serve on that committee along with several others from around the county with different professional backgrounds. The main item for discussion was to evaluate the impacts of the COVID-19 pandemic on agriculture and agritourism in Centre County.
5. A Police Pension Committee meeting was held on April 22<sup>nd</sup> with PNC Bank, the co-fiduciary of the Township's Defined Benefit retirement plan for uniformed employees (police). The plan performance is quite strong and remains over 88% funded.
6. The Pine Grove Mills Small Area Plan Advisory Committee met on April 22<sup>nd</sup>. The main agenda items included continuing refinement of the priorities and implementation guide for the Small Area Plan. Also discussed was the application to the HVAB Tourism Grant, and the Committee provided a letter of support for the Township's application.
7. The Tom Tudek Memorial Park Trust met on April 29<sup>th</sup> to consider expanding the dog park at Tudek Park by adding a large dog enclosure. The additional enclosure is shown on the Park Master Plan. The discussion is very preliminary at this point and no action was taken on the request. Also discussed was the upcoming 2021 Centre Gives Campaign. All are encouraged to participate and contribute to the Tom Tudek Memorial Park Trust for the campaign beginning on May 11<sup>th</sup> and ending May 12<sup>th</sup>.

Township Manager David Pribulka  
3147 Research Dr  
State College, PA 16801

Dear Tree City USA Supporter,

On behalf of the Arbor Day Foundation, I write to congratulate Ferguson Township on earning recognition as a 2020 Tree City USA. Residents of Ferguson Township should be proud to live in a community that makes the planting and care of trees a priority.

Ferguson Township is one of more than 3,600 Tree City USA communities, with a combined population of 155 million. The Tree City USA program is sponsored by the Arbor Day Foundation in partnership with the U.S. Forest Service and the National Association of State Foresters.

If ever there was a time for trees, now is that time. Communities worldwide are facing issues with air quality, water resources, personal health and well-being, and energy use. Ferguson Township is stepping up to do its part. As a result of your commitment to effective urban forest management, you are helping to provide a solution to these challenges.

We hope you are excited to share this accomplishment. Enclosed in this packet is a press release for your convenience as you prepare to contact local media and the public.

State foresters coordinate the presentation of the Tree City USA recognition materials. We will forward information about your awards to your state forester's office to facilitate presentation. It would be especially appropriate to make the Tree City USA award a part of your community's Arbor Day ceremony.

Again, we celebrate your commitment to the people and trees of Ferguson Township and thank you for helping to create a healthier planet for all of us.

Best Regards,



Dan Lambe  
President

cc: Lance King

enclosure





---

# TOWNSHIP OF FERGUSON

3147 Research Drive • State College, Pennsylvania 16801

Telephone: 814-238-4651 • Fax: 814-238-3454

---

## **Public Works Director's Report to the Board of Supervisors (BOS) for the regular meeting on May 5, 2021**

- 1. Public Works Road Crew Activities –** Work activities the week of May 3<sup>rd</sup> include brush collection and leaf collection, and landscaping at the Township building complex. Vehicle maintenance is ongoing. Tudek Park and Cecil Irvin Park will be mowed the week of May 10<sup>th</sup>. Other activities the week of May 10<sup>th</sup> include traffic signal inspections, roadside mowing and watering trees.
- 2. Arborist and Tree Commission Activities-** The FTTC meets next on May 17<sup>th</sup>. Invited guest panelists from Ferguson Township staff and ABCs, COG, the County, and PSU Sustainability Institute will be discussing initiatives to green the community. After May 7<sup>th</sup>, the Public Works Director will serve as the main staff point of contact on tree related matters.
- 3. Stormwater Fee –** Staff meets bi-weekly to review progress on efforts needed to ensure a smooth and effective implementation of a stormwater fee. Activities include quality control and updates/revisions to the GIS impervious layer assignment, finalizing the master account file, coordination with our third party billing agency, public communication and continued education outreach, creating fillable application forms using Laserfishe that can be accessed on line by property owners to apply for credits, partial agriculture exemption, financial/economic hardship exemption, and non-profit exemption.
- 4. Contract 2016-C11 Traffic Signal Performance Metrics –** Design work on this project continues.
- 5. Contract 2018-C20 Park Hills Drainageway –**Design work continues. Completion of design, permitting, easement acquisition, utility relocation this year are needed to progress the project toward construction in 2022.
- 6. Contract 2019-C21 Pine Grove Mills Street Light Conversion:** Design work continues. Entered into a phase 2 design agreement with Barton Associates for electrical design.
- 7. Contract 2020-C18 Science Park and Sandy Drive Signal Design –** Design of the traffic signal will be completed in-house for bidding and construction in 2021. Signal design is progressing with the next step being utility coordination and subsurface utility engineering.
- 8. Contract 2020-C20 Pine Grove Mills Mobility Study –** A contract for this study has been awarded to McCormick Taylor, but a notice to proceed has not been issued due to the coronavirus pandemic which has affected traffic volumes. Staff and consultant are monitoring

traffic volumes and activities to determine an appropriate time to begin the project. This project is currently on hold.

9. **Contract 2020-C21 Pine Grove Road & Water Street/Nixon Road Signal Warrant Study** – A contract for this study has been awarded to McCormick Taylor, but a notice to proceed has not been issued due to coronavirus pandemic which has affected traffic volumes. This project is on hold.
10. **Contract 2021-C2 Devonshire Drive Inlet Box** – [A no cost contract time extension was granted to Ameron to complete this work.](#)
11. **Contract 2021-C3 Cured in Place Pipe Lining** – This project includes lining old corrugated metal storm pipes predominately in the Brackenridge neighborhood based on a completed video assessment of the pipes.
12. **Contract 2021-C5 Storm Sewer Cleaning and Video Assessment** – This project includes cleaning existing storm pipes and televising the system to document the condition of pipes.
13. **Contract 2021-C 8 Pavement Markings** – This work was awarded. Work is planned the week of May 3<sup>rd</sup>.
14. **Contract 2021-C9 Microsurfacing** – This work was awarded. Work is planned for July and August.
15. **Contract 2021-C10 Sealcoat bikepaths** – Certain bikepaths and multi-use paths are sealcoated to extend the life of the asphalt path. In advance of work, FTPW will edge and sweep the paths, seal any cracks, and repair the asphalt as needed. Work is performed in the summer months. This project is out to bid for an opening on May 11<sup>th</sup>.
16. **Contract 2021-C11 Sidewalk Repairs** – [FTPW Engineering Section completed inspection of a portion of the public sidewalks. Property owners will be sent notices to fix deficient sidewalk sections and given an opportunity to fix it themselves or have the Township perform the work by contract and bill the property owner. A contract to repair the concrete sidewalks is out to bid for an opening May 11<sup>th</sup>.](#)
17. **Contract 2021-C12 Traffic Signal Cabinet Installation** – Work includes upgrading the cabinet at the intersection of Science Park Road and West College Avenue
18. **Contract 2021-C13 Traffic Signal LED Replacements** – Signal LEDs are replaced approximately every 7 years.
19. **Contract 2021-C14 Traffic Signal UPS Batteries** – Batteries are needed in the event of power outages and are replaced at the end of their useful life.
20. **Contract 2021-C15 Street Tree Pruning** – Each year a certain number of street trees are pruned to include shaping, clearance, deadwood removal, and hazard mitigation.
21. **Contract 2021-C16 Chesapeake Bay Pollutant Reduction Plan (CBPRP) Design and Permitting** – In compliance with our MS4 permit and CBPRP, certain projects will be advanced through the design and permitting phase.

22. **Contract 2021-C17 Guide Rail Replacement** – Quotes are obtained to replace certain sections of guiderail as needed.
23. **Contract 2021-C18 Homestead Park Play Equipment Installation** – [Ferguson Township Public Works is finishing site restoration.](#)
24. **Contract 2021-C19 Louise E. Silvi Baseball Field Fence Installation** – Work includes replacement of a section of ball field fence.
25. **Contract 2021-C20 Songbird Sanctuary Plan Implementation** – A yet to be formalized scope of work including a perimeter walking path and tree planting will be moved forward by FTPW.
26. **Contract 2021-C21 Signal Luminaire Conversion to LED** – This project includes converting select overhead lighting at traffic signal intersections from high pressure sodium to LED.
27. **Contract 2021-C22 Playground Safety and Update Program** – Each year funding is provided to update playground equipment found to be deficient based on playground inspections. No project has yet been assigned to FTPW for this year.
28. **Contract 2021-C23 Traffic Signal Pole Replacement** – Work includes replacement of a traffic signal pole at the intersection of West College Avenue and Science Park Road. The pole was damaged in a vehicle accident. The contract was awarded.
29. **Asset Management and Work Order Software** – Staff continues to evaluate Dude Solutions and is evaluating TRAISR software.

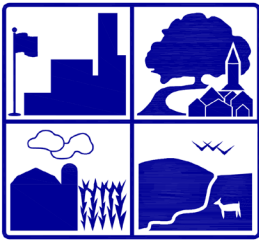

# TOWNSHIP OF FERGUSON

3147 Research Drive • State College, Pennsylvania 16801  
Telephone: 814-238-4651 • Fax: 814-238-3454  
[www.twp.ferguson.pa.us](http://www.twp.ferguson.pa.us)

## PLANNING & ZONING DIRECTOR'S REPORT

Monday, May 3, 2021

### PLANNING COMMISSION

The Planning Commission will be meeting May 10<sup>th</sup> to review a Conditional Use application.

### LAND DEVELOPMENT PLANS AND OTHER PROJECTS

1. Active Plans are listed below for the Board of Supervisors (04/14/2021).
  - Orchard View Subdivision (24-004-,067)
  - State College Borough Water Authority (24-006-055E)
  - West College Student Housing Lot Consolidation and Land Development Plan (24-002A-015; 24-002A-016; 24-002A-017; 24-002A-018; and 36-010-006)
  - Wasson/Ash Ave. Subdivision Plan (24-002A-132; 24-002A-134; 24-002A-135)
  - Sycamore Drive Subdivision (24-009A-254)
2. PZ Staff and Township Engineer met with an applicant to discuss a subdivision plan submission.
3. PZ Director and Zoning Administrator met with the Township Solicitor to discuss pending litigation.
4. PZ Staff met with a resident to discuss a potential minor subdivision, a potential ordinance amendment request and with Local Little League/Softball Representation on a potential land development plan.
5. PZ Staff met with COG Representatives to discuss phases of their approved Whitehall Road Regional Park land development plan.
6. Community Planner and PZ Director attended the CRPA/Municipal Staff Meeting.
7. PZ Director attended the Leadership Team Meeting, Board of Supervisors Executive Sessions, the Pine Grove Mills Advisory Committee Meeting, the Public Works Ribbon Cutting Ceremony, and the Community Resilience Building Workshop.
8. Community Planner and PZ Director attended the CRPA/Municipal Staff Meeting.

### ZONING HEARING BOARD

Zachary Maser—310 Marengo Lane (24-006A-081), zoned Single Family Residential (R1), is requesting a variance from §27-701.3.C.1—Use Limitations and §27-701.3.I.—Use Buffer to allow for the applicant to repair and pave the existing driveway that is located in the floodplain.