



## TOWNSHIP OF FERGUSON

3147 Research Drive • State College, Pennsylvania 16801  
Telephone: 814-238-4651 • Fax: 814-238-3454  
www.twp.ferguson.pa.us

### Parks and Recreation Committee Meeting Agenda

Thursday, October 15, 2020, 4:00 p.m.

Join Zoom Meeting: <https://us02web.zoom.us/j/81710779501?>

Dial In: 1 646 558 8656

Meeting ID: 817 1077 9501      Passcode: 135293

- I. CALL TO ORDER
- II. CITIZEN'S INPUT
- III. APPROVAL OF MINUTES
- IV. FAIRBROOK PLAYGROUND EQUIPMENT

In 2019, the Township Playground Inspection report noted that the secondary play area with small play structures, at Fairbrook Park, are older and should be replaced with new equipment. Attached with the agenda are two options including cost estimates for the replacement for review by the Parks and Recreation Committee. Both options use the same playground equipment, however, there are differences between the two options. Option one utilizes the existing fall surface area which would require excavation under several of the trees drip line. Option two will shift the fall surface and minimize excavation under the trees. Both options move the smaller fall pit surface to the north (or to the right of the large pit as shown on the drawings) so excavation is minimized under existing tree drip lines. Following a site visit, staff recommends moving smaller equipment pit as roots are visible in proximity and likely to encounter roots throughout this area during replacement. Staff's recommendation is to consider option 2 as it minimizes disturbance to existing trees.

#### STAFF RECOMMENDATION

That the Committee *approve* option 2 for the Fairbrook Park lower playground replacement.

#### V. UPDATE ON INATURALIST

iNaturalist is a smart-device app that can record and share natural history observations. It is used by amateurs and professionals alike to keep and share records of what plants and animals they saw, where and when they saw them, and an image of what they saw. Mr. Muth and his student, Ms. Hanna Hauck, are in attendance to present on how this tool could be used to in our park for a discussion. Mr. Muth and Ms. Hauck have updates and ready to share a demo on new stuff that they would benefit from having additional feedback from the Parks and Recreation Committee.

#### STAFF RECOMMENDATION

That the Committee receive updates and provide comment.

#### VI. REPORTS

1. Staff Report
2. Centre Region Parks and Recreation Authority Report – Mr. Bill Keough

**VII. COMMUNICATIONS TO THE PARKS AND RECREATION COMMITTEE**

**VIII. FUTURE REQUESTS FOR AGENDA ITEMS**

**IX. OPEN DISCUSSION**

**X. ADJOURNMENT**

**FERGUSON TOWNSHIP PARKS AND RECREATION COMMITTEE**  
**MEETING MINUTES**  
**THURSDAY, SEPTEMBER 17, 2020**  
**4:00 P.M.**

**I. ATTENDANCE**

The Parks and Recreation Committee held its regular meeting on Thursday, September 17, 2020, via Zoom in attendance were:

**Committee:**

Norris Muth- Chairperson  
Tessa Antolick- Vice Chair-Absent  
Dr. Shawna Doerksen-Secretary  
Connie Puckett  
Robert Demayo-Absent  
Bill Keough  
Jerry Learn  
Rick Tetzlaff

**Staff:**

David Pribulka, Township Manager  
Centrice Martin, Assistant to the Manager  
Lance King, Township Arborist

Others in attendance: Summer Krape, Recording Secretary; Laura Dininni, Ferguson Township Resident & Board of Supervisors member.

**II. CALL TO ORDER**

Mr. Norris Muth called the Thursday, September 17, 2020 Park and Recreation meeting to order at 4:04 pm. Mr. David Pribulka went over the procedures for a ZOOM meeting.

**III. CITIZEN'S INPUT**

**IV. APPROVAL OF MINUTES**

Mr. Muth called for a motion to approve the August 20, 2020 minutes Dr. Shawna Doerksen made a motion to approve the minutes, Mr. Rick Tetzlaff seconded the motion, and the motion passed unanimously.

**V. PRESENTATION ON COMMUNITY ORCHARDS**

Mr. Lance King stated that he was asked to attend today's meeting to discuss community orchards. Mr. King stated that the Township was approached by a resident that requested a community orchard. Mr. King stated that he has done some research and sent some information from the Philadelphia orchard program to the Committee members prior to this meeting. Mr. King stated that he is not an expert in orchards however; he does know that orchards are pretty labor intensive. Mr. King's main suggestion is that the Township would need to have an engaged and energetic group to take care of the orchard. Mr. King went over the information he sent to the Committee members from the Philadelphia orchard program. Mr. Jerry Learn asked if there was one person or more than one that was interested in doing the community orchard. Mr. Learn agrees that they are a lot of work as he has personal experience. Mr. Learn stated some administrative problems with an orchard.

Mr. Centrice Martin stated that the inquiry she received was from an individual that has an affiliation with Penn State, but it was unclear if this was one person or more. The individual was interested in planting peach, pear, and apricot trees. Ms. Martin stated that the Township has allocated a small amount of funds for a community orchard in the CIP. Mr. Rick Tetzlaff stated that a resident contacted him as well. Mr. Tetzlaff stated his concern that this could be a direct competition with grocery stores, Harner Farm, and Ways Fruit Farm. Mr. Tetzlaff stated that the Committee needs to take in account the possibility of the fruit attracting nuisance animals. Ms. Laura Dininni stated that the most recent survey

done by the Centre Region Council of Governments Office stated interest in community orchards but acknowledged the lack of programming for nature based programs. Ms. Dininni stated that she feels there is an interest in it but she also acknowledges all of the pitfalls. The Committee continued to discuss the topic. Dr. Muth suggested some small steps would be to determine what kind of trees would be planted if the opportunity arises. Mr. Jerry Learn suggested talking with the people that are interested and asking what they want.

**VI. 2021 OPERATING BUDGET FOR PARK IMPROVEMENT UPDATE**

Ms. Martin stated that staff is beginning to review the budget and will be making recommendation to the manager then those recommendations will be reported to the BOS for adoption into the operating budget for 2021. Ms. Martin stated she will be working with the manager in the upcoming weeks and this will be presented to the Committee before it goes to the board.

**VII. REVIEW OF TOWNSHIP PARK ORDINANCE**

Mr. Pribulka stated that staff just wanted to get this ordinance in front of the Committee. The BOS has not seen this ordinance yet, this will be present to the BOS in October. Mr. Pribulka stated that this is a regional effort but was halted due to COVID-19. The goal is to have a standardized ordinance governing parks and recreation.

**VIII. COMMITTEE REQUEST- ACQUISITION OF PARKLAND**

**IX. REPORTS**

**1. STAFF REPORT**

Ms. Martin stated that there are four items she would like to touch on. There has been an update on drafted green infrastructure policy, staff met with the Centre Region. Ms. Martin stated that she is currently working on compiling notes to present to the Committee. Centre Region Fall Bike program will be on the next BOS agenda for adoption. Ms. Martin stated that she met with Mrs. Tess Antolick Committee vice chair and Mr. Learn discuss the land development subcommittee. Ms. Martin also noted that an injury occurred at Homestead Park, staff performed an inspection on the two play structures and the equipment is now unavailable to the public at this time. A repair kit has been purchased.

**2. CENTRE REGION PARKS AND RECREATION AUTHORITY REPORT – MR. BILL KEOUGH**

Mr. Bill Keough stated that the Park Authority is still looking for a CNET representative and explained what the position would require. Mr. Keough updated the Committee on the Millbrook Marsh boardwalk issue, the Authority awarded a feasibility study on what needs done and how to a company. Whitehall road Regional Park the Authority approved the initial bid documents for the Whitehall Road Regional Park and they will be distributed in the near future.

**X. COMMUNICATION TO PARKS AND RECREATION COMMITTEE**

**XI. FUTURE REQUESTS FOR AGENDA ITEMS**

Dr. Muth suggested making iNaturalist a future agenda item to update the Committee.

**XII. OPEN DISCUSSION**

**XIII. ADJOURNMENT**

Dr. Muth made a motion to adjourn the Thursday, September 17, 2020 Parks and Recreation meeting at pm. Mr. Tetzlaff seconded the motion and the motion passed unanimously.

RESPECTFULLY SUBMITTED,

---

SHAWNA DOERKSEN, SECRETARY  
FOR THE PARKS AND RECREATION COMMITTEE

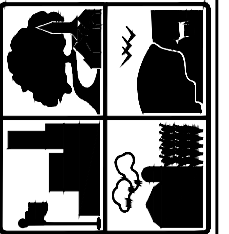

**FERGUSON TOWNSHIP**  
 DEPT. OF PUBLIC WORKS & ENGINEERING  
 3147 RESEARCH DRIVE  
 STATE COLLEGE, PA 16801  
 PHONE: 814-238-4651  
 FAX: 814-238-3454  
 www.twp.ferguson.pa.us

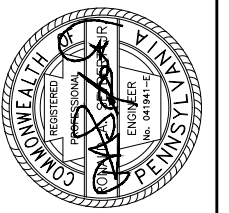

REV.	DATE

FAIRBROOK PARK  
 LOWER PLAYGROUND REPLACEMENT

**OPTION 1 PLAN**

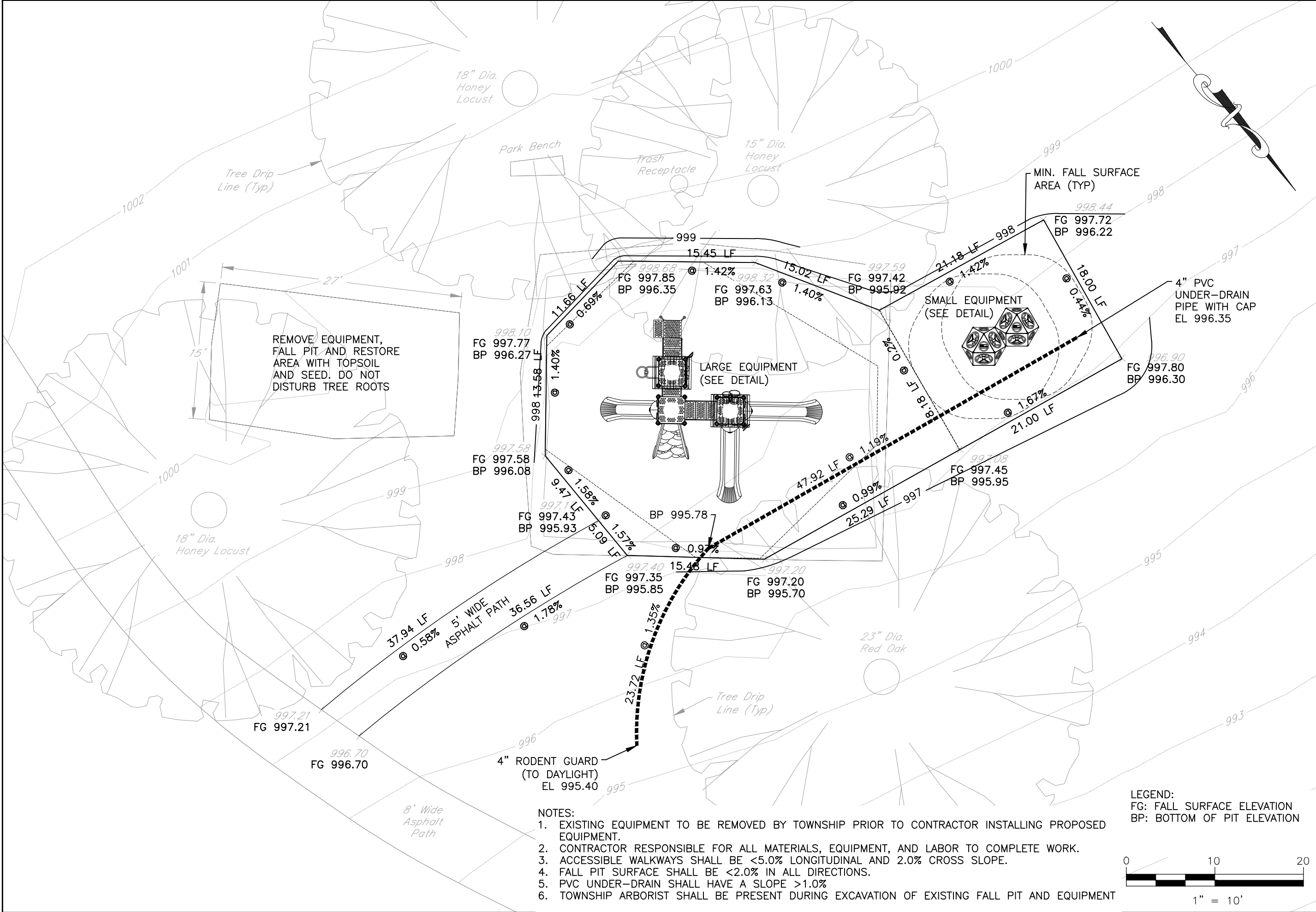

**NOTES:**

- EXISTING EQUIPMENT TO BE REMOVED BY TOWNSHIP PRIOR TO CONTRACTOR INSTALLING PROPOSED EQUIPMENT.
- CONTRACTOR RESPONSIBLE FOR ALL MATERIALS, EQUIPMENT, AND LABOR TO COMPLETE WORK.
- ACCESSIBLE WALKWAYS SHALL BE <5.0% LONGITUDINAL AND 2.0% CROSS SLOPE.
- FALL PIT SURFACE SHALL BE <2.0% IN ALL DIRECTIONS.
- PVC UNDER-DRAIN SHALL HAVE A SLOPE >1.0%
- TOWNSHIP ARBORIST SHALL BE PRESENT DURING EXCAVATION OF EXISTING FALL PIT AND EQUIPMENT

**LEGEND:**  
 FG: FALL SURFACE ELEVATION  
 BP: BOTTOM OF PIT ELEVATION

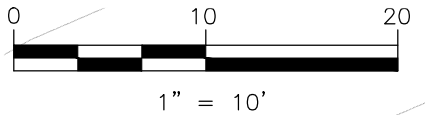

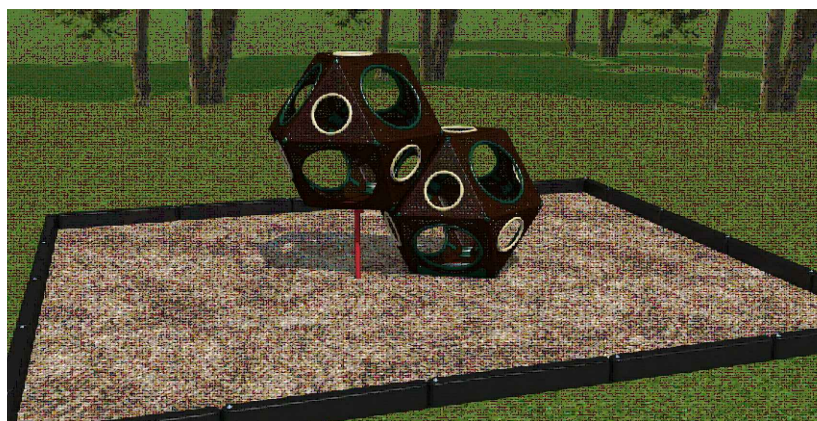

SMALL EQUIPMENT  
NOT TO SCALE

NOTES:

1. CUBES TO BE ROTOMOLDED PLASTIC CUBES NOT METAL AS SHOWN IN PICTURE.

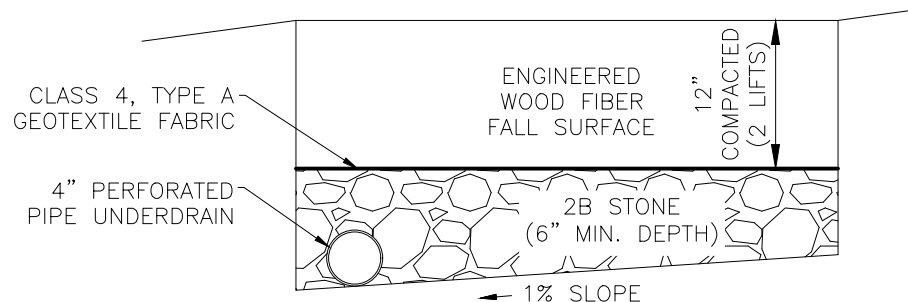

PLAY EQUIPMENT PIT SECTION VIEW  
NOT TO SCALE

WMA BINDER COURSE, PG64-22, <0.3  
ESALS, 19MM, SRL-L, 3" DEPTH

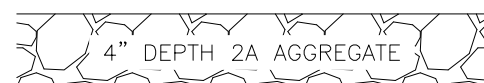

ACCESSIBLE ROUTE  
NOT TO SCALE

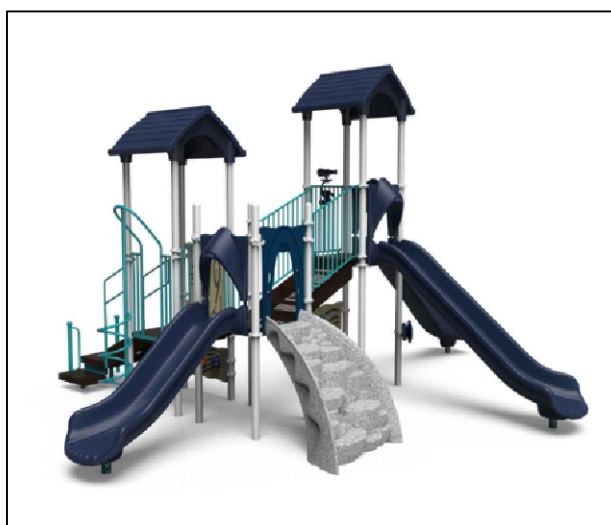

LARGE EQUIPMENT  
NOT TO SCALE

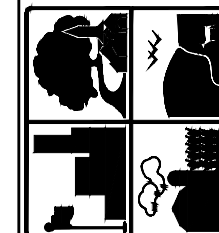

**FERGUSON TOWNSHIP**  
DEPT. OF PUBLIC WORKS & ENGINEERING  
3147 RESEARCH DRIVE  
STATE COLLEGE, PA 16801  
PHONE: 814-238-4651  
FAX: 814-238-3454  
www.twp.ferguson.pa.us

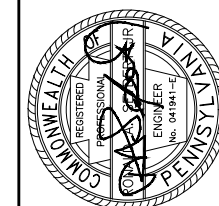

REV.	DATE

FAIRBROOK PARK  
LOWER PLAYGROUND REPLACEMENT

**DETAILS**

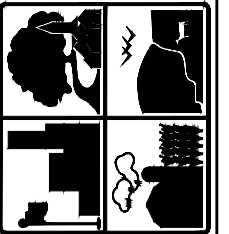

**FERGUSON TOWNSHIP**  
 DEPT. OF PUBLIC WORKS & ENGINEERING  
 3147 RESEARCH DRIVE  
 STATE COLLEGE, PA 16801  
 PHONE: 814-238-4651  
 FAX: 814-238-3454  
 www.twp.ferguson.pa.us

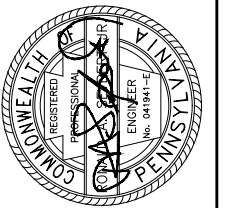

REV.	DATE

FAIRBROOK PARK  
 LOWER PLAYGROUND REPLACEMENT

**OPTION 2 PLAN**

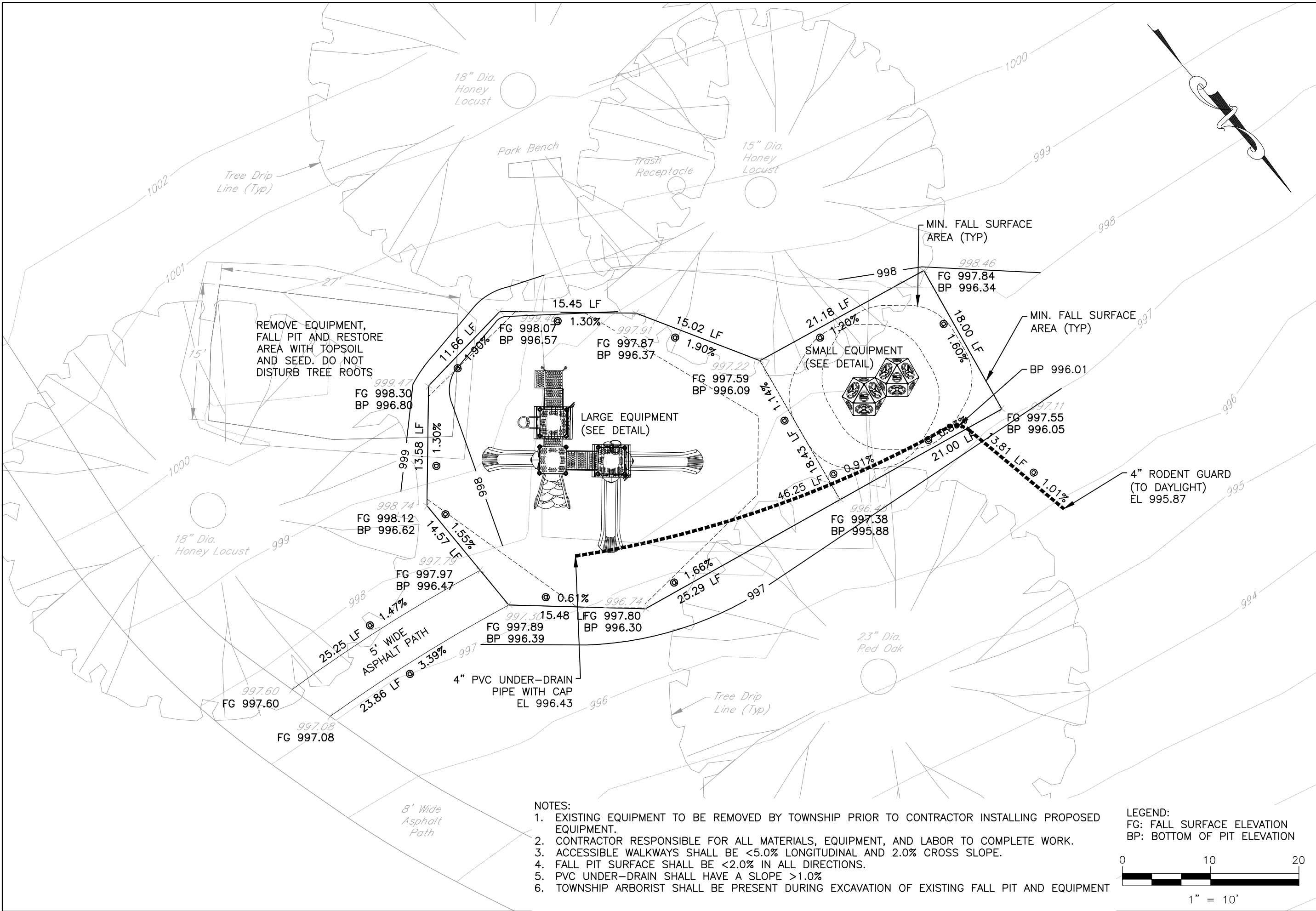

- NOTES:
- EXISTING EQUIPMENT TO BE REMOVED BY TOWNSHIP PRIOR TO CONTRACTOR INSTALLING PROPOSED EQUIPMENT.
  - CONTRACTOR RESPONSIBLE FOR ALL MATERIALS, EQUIPMENT, AND LABOR TO COMPLETE WORK.
  - ACCESSIBLE WALKWAYS SHALL BE <5.0% LONGITUDINAL AND 2.0% CROSS SLOPE.
  - FALL PIT SURFACE SHALL BE <2.0% IN ALL DIRECTIONS.
  - PVC UNDER-DRAIN SHALL HAVE A SLOPE >1.0%
  - TOWNSHIP ARBORIST SHALL BE PRESENT DURING EXCAVATION OF EXISTING FALL PIT AND EQUIPMENT

LEGEND:  
 FG: FALL SURFACE ELEVATION  
 BP: BOTTOM OF PIT ELEVATION

1" = 10'



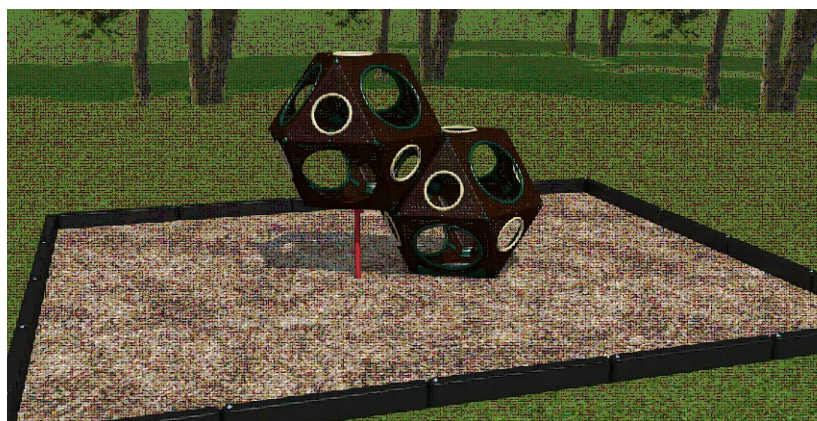

SMALL EQUIPMENT  
NOT TO SCALE

- NOTES:  
1. CUBES TO BE ROTOMOLDED PLASTIC CUBES NOT METAL AS SHOWN IN PICTURE.

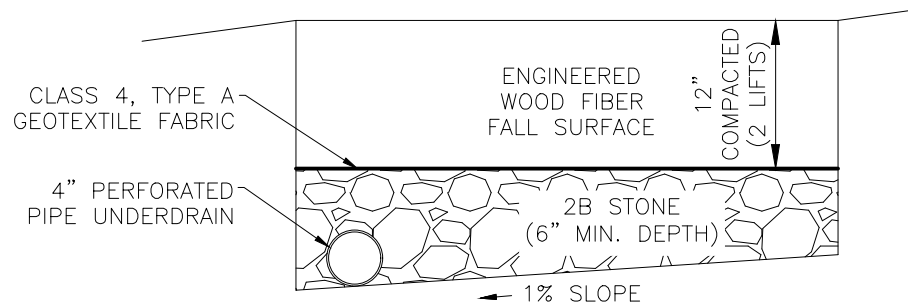

PLAY EQUIPMENT PIT SECTION VIEW  
NOT TO SCALE

WMA BINDER COURSE, PG64-22, <0.3 ESALS, 19MM, SRL-L, 3" DEPTH

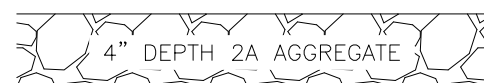

ACCESSIBLE ROUTE  
NOT TO SCALE

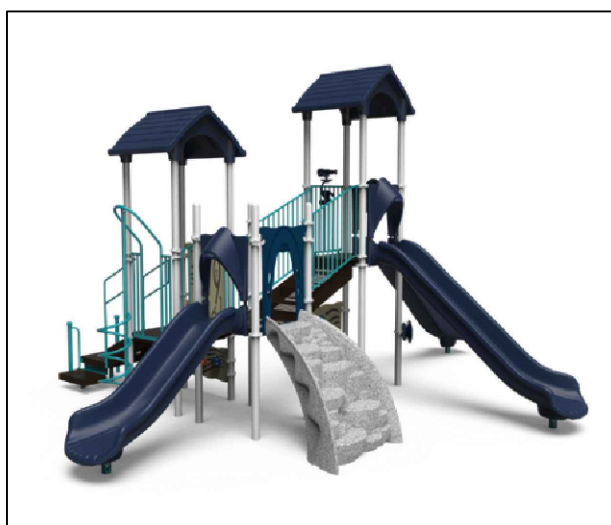

LARGE EQUIPMENT  
NOT TO SCALE

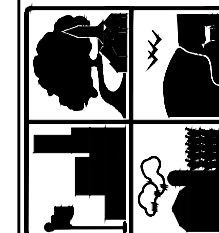

**FERGUSON TOWNSHIP**  
DEPT. OF PUBLIC WORKS & ENGINEERING  
3147 RESEARCH DRIVE  
STATE COLLEGE, PA 16801  
PHONE: 814-238-4651  
FAX: 814-238-3454  
www.twp.ferguson.pa.us

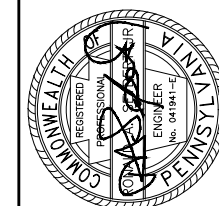

REV.	DATE

FAIRBROOK PARK  
LOWER PLAYGROUND REPLACEMENT

**DETAILS**

**FAIRBROOK PARK PLAYGROUND IMPROVEMENTS**  
 Project # 2020-C22  
 Engineers Estimate

**GEORGE ELY ASSOCIATES**

QTY	ITEM No. UNIT	DESCRIPTION	GEI UNIT PRICE	TOTAL	NOTES
1	9000 0001 EA	RISE ABOVE FUN-1487	\$16,292.00	\$16,292.00	GEA Quote
1	9000 0002 EA	RISE ABOVE FUN-1487 INSTALLATION	\$8,964.00	\$8,964.00	GEA Quote
1	9000 0003 EA	2-CUBE ROTO-MOLDED PlayCube (2 x 20-2358A)	\$5,817.00	\$5,817.00	GEA Quote
1	9000 0004 EA	2-CUBE ROTO-MOLDED PlayCube (2 x 20-2358A) INSTALLATION	\$1,956.00	\$1,956.00	GEA Quote
<b>GEA SUB-TOTAL</b>				<b>\$33,029.00</b>	
<b>Budget</b>				\$37,500.00	
Equipment items purchased to date for repairs				\$2,500.00	
Remaining Funds Available				\$35,000.00	

**PUBLIC WORKS TO PERFORM IN-HOUSE**

**OTPION 1**

QTY	ITEM No. UNIT	DESCRIPTION	UNIT PRICE	TOTAL	NOTES
70	9000 0005 CY	ENGINEERED WOOD FIBER (MATERIAL ONLY)	\$22.19	\$1,553.38	Used 2018 unit price and inflated to 2020 dollars. Increased qty. by 20%
1	9000 0006 ROLL	CLASS 4, TYPE A GEOTEXTILE	\$750.48	\$750.48	www.landscapediscount.com, Roll is \$708 for 15' x 360' = 4590 SF
73	9000 0007 LF	4" PERF. UNDER-DRAIN PIPE (ONLY MATERIAL)	\$ 1.00	\$73.00	Lowes.com \$73.35 for 100'
50	9000 0008 TON	SUBBASE 6" DEPTH (2B) UNDER-DRAIN (MAERIAL ONLY)	\$ 13.50	\$675.00	2020-C7c Unit Price (Hanson)
12	9000 0009 CY	TOPSOIL	\$ 60.00	\$720.00	Used 2020-C1 NESL unit price. Assumed 4' around parimeter of new paths
81	9000 0010 SY	SEEDING AND SOIL SUPPLEMENTS AND MULCHING	\$ 2.80	\$226.80	Used Ameron unit price from 2020-C1.
4	9000 0011 TON	19.0 MM WEARING, SRL-L PG 64-22, <0.3 MILLION ESALS (ADA ACCESSIBLE SIDEWALK (3" DEPTH))	\$52.08	\$208.30	Used avg. unit price for 9.5 & 25 mm in 2020-C7c unit price (HRI)
3	9000 0012 TON	2A STONE (4" THICK FOR UNDER PAVED ACCESSIBLE SIDEWALK)	\$11.75	\$35.25	Used 2020-C7c unit price (Hanson)
1	9000 0013 EA	REMOVE AND DISPOSE OF EXISTING EQUIPMENT	\$0.00	\$0.00	
<b>TOTAL</b>				\$4,242.21	
20% <b>CONTINGENCY</b>				\$848.44	
<b>PW SUB-TOTAL</b>				<b>\$5,090.65</b>	

**TOTAL PROJECT COST \$38,119.65**

**BUDGET = \$ 35,020.79** subtracted improvements from Saybrook and Homestead parks

**OTPION 2**

QTY	ITEM No. UNIT	DESCRIPTION	UNIT PRICE	TOTAL	NOTES
70	9000 0005 CY	ENGINEERED WOOD FIBER (MATERIAL ONLY)	\$22.19	\$1,553.38	Used 2018 unit price and inflated to 2020 dollars. Increased qty. by 20%
1	9000 0006 ROLL	CLASS 4, TYPE A GEOTEXTILE	\$750.48	\$750.48	www.landscapediscount.com, Roll is \$708 for 15' x 360' = 4590 SF
61	9000 0007 LF	4" PERF. UNDER-DRAIN PIPE (ONLY MATERIAL)	\$ 1.00	\$61.00	Lowes.com \$73.35 for 100'
50	9000 0008 TON	SUBBASE 6" DEPTH (2B) UNDER-DRAIN (MAERIAL ONLY)	\$ 13.50	\$675.00	2020-C7c Unit Price (Hanson)
6	9000 0009 CY	TOPSOIL	\$ 60.00	\$360.00	Used 2020-C1 NESL unit price. Assumed 4' around parimeter of new paths
78	9000 0010 SY	SEEDING AND SOIL SUPPLEMENTS AND MULCHING	\$ 2.80	\$218.40	Used Ameron unit price from 2020-C1.
3	9000 0011 TON	19.0 MM WEARING, SRL-L PG 64-22, <0.3 MILLION ESALS (ADA ACCESSIBLE SIDEWALK (3" DEPTH))	\$52.08	\$156.23	Used avg. unit price for 9.5 & 25 mm in 2020-C7c unit price (HRI)
3	9000 0012 TON	2A STONE (4" THICK FOR UNDER PAVED ACCESSIBLE SIDEWALK)	\$11.75	\$35.25	Used 2020-C7c unit price (Hanson)
1	9000 0013 EA	REMOVE AND DISPOSE OF EXISTING EQUIPMENT	\$0.00	\$0.00	
<b>TOTAL</b>				\$3,809.73	
20% <b>CONTINGENCY</b>				\$761.95	
<b>PW SUB-TOTAL</b>				<b>\$4,571.68</b>	

**TOTAL PROJECT COST \$37,600.68**

**BUDGET = \$ 35,020.79** subtracted improvements from Saybrook and Homestead parks



a

**Staff Report  
October 15, 2020**

1. Staff presented to the Board of Supervisors on September 21, 2020 the drafted Green Infrastructure Policy. Staff received comment from the Board and then compiled meeting notes from meetings with Parks Committee, Centre Region Parks Recreation staff and the Board. Staff will edit and update the drafted policy for the Board's consideration.
2. Staff continues to work on a solution for the safety concerns presented at Homestead Park over the playground equipment.
3. Staff received notification from Pennsylvania Department of Conservation a Natural Resources (DCNR) that Ferguson Township was awarded the Community Conservation Partnership Program (C2P2) grant which is a match for the construction of Suburban Park Phase 1. Furthermore, DCNR recommended this project to be considered for federal funds from the Land and Water Conservation Program administered by the National Park Service. Staff is working to prepare required materials to submit for the federal funds through the LWCP.